



## Zoning Resolution

THE CITY OF NEW YORK

Eric Adams, Mayor

CITY PLANNING COMMISSION

Daniel R. Garodnick, Chair

# **62-341 - Developments on land and platforms**

File generated by <https://zr.planning.nyc.gov> on 12/21/2024

---

## 62-341 - Developments on land and platforms

---

LAST AMENDED

6/6/2024

All #developments# on portions of a #zoning lot# landward of the #shoreline# or on #platforms# shall be subject to the height and setback provisions of this Section. However, when the seaward view from all points along the #shoreline# of a #zoning lot# is entirely obstructed by existing elevated roads, bridges or similar structures which are less than 50 feet above mean high water and within 200 feet of the #shoreline#, #developments# shall be exempt from the requirements of this Section. Height and setback regulations for #developments# on #piers# and #floating structures# are set forth in Sections [62-342](#) and 62-343.

(a) For the purposes of applying the height and setback regulations of this Section, the following provisions shall apply:

(1) #Street lines#

For the purposes of paragraphs (c) and (d) of this Section and of paragraph (h) of Section [62-354](#), a #shore public walkway#, #visual corridor#, #upland connection# or #supplemental public access area# shall be considered a #street# and its boundary shall be treated as a #street line#. Any #visual corridor# or #upland connection# that measures at least 75 feet in width, or any #shore public walkway# or #supplemental public access area#, shall be considered a #wide street#. Any other #visual corridor# or #upland connection# shall be considered a #narrow street#.

(2) #Initial setback distance#

For the purposes of paragraph (c) of this Section, an #initial setback distance# shall be a horizontal distance measured for a depth of 15 feet from a #narrow# #street line# and 10 feet from a #wide# #street line#. However, an #initial setback distance# shall have a depth of 30 feet from the boundary of a #shore public walkway#. Wherever a #supplemental public access area# is provided as a widened #shore public walkway#, such widened area shall be included in the #initial setback distance#.

(3) Measurement of height

The height of all #buildings or other structures# on #waterfront blocks# shall be measured from the #base plane#, except where modified by the provisions of Article VI, Chapter 4. For #buildings# with pitched roofs, maximum #building# height shall be measured to the midpoint of such pitched roof, except for #buildings# subject to Section [23-631](#) (General provisions).

(4) Permitted obstructions

The obstructions permitted pursuant to Sections [23-62](#), inclusive, [24-51](#), [33-42](#) or [43-42](#) and, where applicable, Sections [64-331](#), [64-332](#) or [64-432](#), shall apply. In addition, the following regulations regarding permitted obstructions shall apply:

- (i) Within an #initial setback distance#, a dormer may exceed a maximum base height specified in Table A of this Section or penetrate a required setback area above a maximum base height specified in paragraph (d) of this Section, provided that such dormer complies with the provisions of paragraph (c)(1) of Section 23-623.
- (ii) A penthouse portion of a #building# shall be permitted to exceed the applicable maximum #building# height, specified in Table A, by not more than 40 feet, only if the gross area of any #story# within such portion has a #lot coverage# of at least 50 percent and not more than 85 percent of the highest #story# that

is located entirely below the maximum #building# height. Such reduced #lot coverage# shall be achieved by one or more setbacks on each face of the penthouse portion, where at least one setback on each face has a depth of at least four feet and a width that, individually or in the aggregate, is equal to at least 10 percent of the width of such respective face. For the purposes of this paragraph, (a)(4)(ii), the penthouse portion shall have four faces, with each face being the side of the rectangle within which the outermost walls of the highest #story# located entirely below the maximum #building# height have been inscribed. The required setbacks shall be measured from the outermost walls of the #building# facing each penthouse portion face. Required setback areas may overlap.

(iii) Wind energy systems

Regulations governing wind energy systems are modified pursuant to this paragraph, (a)(4)(iii).

In R6 through R10 Districts, #Commercial Districts#, other than C1 or C2 Districts mapped within R1 through R5 Districts and C4-1 and C8-1 Districts, and #Manufacturing Districts#, other than M1-1 Districts, wind energy systems located on a roof of a #building# shall not exceed a height equivalent to 50 percent of the height of such portion of the #building# or 55 feet, whichever is less, as measured from the roof to the highest point of the wind turbine assembly.

In C4-1, C8-1 and M1-1 Districts, for #buildings# containing #commercial# or #community facility# #uses#, wind energy systems shall not exceed a height of 55 feet when located above a roof of the #building# as measured to the highest point of the wind turbine assembly.

In all districts, no portion of a wind energy system may be closer than 10 feet to a #waterfront public access area# boundary or a #zoning# #lot line#.

(b) Lower density districts

R1 R2 R3 R4 R5 C3 C4-1 C8-1 M1-1

In the districts indicated, and in C1 and C2 Districts mapped within such #Residence Districts#, the underlying district height and setback regulations are applicable or modified as follows:

(1) #Buildings# containing #residences#

- (i) In R1 and R2 Districts, and in #Commercial Districts# governed by the #bulk# regulations of such #Residence Districts#, the underlying height and setback regulations shall not apply. In lieu thereof, no #building# containing #residences#, except for a #predominantly# #community facility building#, shall exceed a height of 35 feet.
- (ii) In R3, R4 and R5 Districts, and in #Commercial Districts# governed by the #bulk# regulations of such #Residence Districts#, the underlying height and setback regulations for #buildings# containing #residences# shall apply, except for #predominantly# #community facility buildings#.

(2) #Predominantly# #community facility buildings#

The underlying height and setback regulations shall not apply. In lieu thereof, any portion of a #predominantly# #community facility building# that exceeds a height of 35 feet shall be set back at least 25 feet from a #front yard line# or #street line#, where applicable, and no portion of such #building# shall exceed a height of 60 feet. However, within a #large-scale community facility development#, for portions of a #building# that are located at

least 100 feet from a #street line# and, on a #waterfront zoning lot#, 100 feet from a #waterfront yard#, the maximum height shall not exceed 100 feet.

(3) #Buildings# containing #commercial# #uses#

The underlying height and setback regulations for #commercial# #uses# are modified as follows: no #building# containing #commercial# #uses# shall exceed a height of 30 feet, except for #mixed buildings# as set forth in paragraph (b)(1) of this Section or #predominantly# #community facility buildings# as set forth in paragraph (b)(2) of this Section.

(4) Other structures

All structures other than #buildings# shall be limited to a height of 35 feet, except that in C4-1, C8-1 and M1-1 Districts, freestanding wind energy systems shall be permitted to a height of 85 feet, as measured from the base plane to the highest point of the wind turbine assembly.

(c) Medium and high density non-contextual districts

R6 R7 R8 R9 R10

C1-6 C1-7 C1-8 C1-9 C2-6 C2-7 C2-8 C4-2 C4-3 C4-4 C4-5 C4-6 C4-7 C5 C6 C8-2 C8-3 C8-4

M1-2 M1-3 M1-4 M1-5 M1-6 M2 M3

Except for medium and high density contextual districts listed in paragraph (d) of this Section, in the districts indicated, and in C1 and C2 Districts mapped within such #Residence Districts#, the underlying height and setback regulations shall not apply. In lieu thereof, the height and setback regulations set forth in this Section shall apply.

(1) Maximum base height

Except for dormers permitted in accordance with paragraph (a)(4)(i) of this Section, the height of a #building# or other structure# or portion thereof located within an #initial setback distance# may not exceed the maximum base height specified in Table A of this Section

(2) Maximum #building# height

Except for penthouses permitted in accordance with paragraph (a)(4)(ii) of this Section, the height of a #building# or other structure# or portion thereof may not exceed the maximum #building# height specified in Table A.

(3) #Floor area# distribution

#Zoning lots# with #buildings# that exceed the maximum base height listed in Table A shall have a minimum #floor area# coverage comprising at least 30 percent of the #lot area# at a height of 20 feet. For the purposes of determining this requirement, the #lot area# of #waterfront zoning lots# shall be deemed to be the area of the #zoning lot# landward of the #shoreline#. In the event the site plan involves construction on only a portion of the #zoning lot#, sufficient calculations shall be provided to show that such partial construction does not preclude compliance with the minimum #floor area# coverage requirements of this Section at the time the site is fully developed.

(4) Maximum #residential# tower size

Each #residential# #story# of a #building# located entirely above the maximum base height specified in Table A shall not exceed a gross area of 7,000 square feet on #zoning lots# less than 1.5 acres, and 8,100 square feet on larger #zoning lots#. On all #zoning lots#, dormers permitted within an #initial setback distance# in accordance with the provisions of paragraph (a)(4)(i) of this Section shall not be included in such gross area.

(5) Maximum width of walls facing #shoreline#

The maximum width of any #story# of a #building# that faces a #shoreline# and is entirely above the maximum base height specified in Table A shall not exceed 100 feet. Such width shall be measured by inscribing within a rectangle the outermost walls at the level of each #story# entirely above the maximum base height. Any side of such rectangle from which perpendicular lines may be drawn to a #shoreline#, regardless of any intervening structures, properties or #streets#, shall not exceed 100 feet. (See illustration).

(6) Ground floor streetscape provisions

For the purposes of this Section, “ground floor level” shall mean the floor of a #building#, the level of which is located within five feet of the finished level of the adjacent sidewalk.

For #street walls# that are more than 50 feet in width and within 50 feet of a #waterfront public access area# or #street#, the following rules shall apply:

- (i) at least 50 percent of the width of such #street walls# shall be occupied by #floor area# at the ground floor level; and
- (ii) where such #street walls# do not contain windows with sill levels lower than four feet above the adjacent sidewalk for a continuous distance of at least 30 feet, such #street walls# shall be articulated with rustication or decorative grills, or screened with plant material, to a minimum height of four feet.

Parking garages that occupy the ground floor frontage along any #street# or private drive which is also an #upland connection# shall be screened in accordance with the planting requirements of paragraph (a)(7)(iii) of Section 62-655.

TABLE A

HEIGHT AND SETBACK FOR ALL BUILDINGS AND OTHER STRUCTURES IN MEDIUM AND HIGH DENSITY NON-CONTEXTUAL DISTRICTS\*

	Maximum Height (in feet)	
District	Maximum Base Height	Maximum Height of #Buildings or other Structures#

R6 C1 or C2 mapped within R6 C8-2 C8-3 M1-2 M1-4 M2-1 M2-3 M3	60	110
R7-1 R7-2 C1 or C2 mapped within R7-1 or R7-2 C1-6 C2-6 C4-2 C4-3 C4-4 C4-5	60	135
R7-3 C1 or C2 mapped within R7-3 C8-4 M1-3 M1-5 M2-2 M2-4	65	185
R8 C1 or C2 mapped within R8 C1-7 C6-1 C6-2	70	210
R9 C1 or C2 mapped within R9 C1-8 C2-7 C6-3	80	225
R9-1 C1 or C2 mapped within R9-1	90	280
R10 C1 or C2 mapped within R10 C1-9 C2-8 C4-6 C4-7 C5-1 C5-2 C5-3 C5-4 C5-5 C6-4 C6-5 C6-6 C6-7 C6-8 C6-9 M1-6	110	350

-----

\* For #predominantly# #community facility buildings#, the applicable regulations shall be determined from Table B of this Section

TABLE B

APPLICABLE HEIGHT AND SETBACK REGULATIONS FOR PREDOMINANTLY COMMUNITY FACILITY BUILDINGS

District in which #Predominantly# #Community Facility Building# is Located	Applicable Regulations from Table A
R6 R7-1 R7-3 C1 or C2 mapped within R6, R7-1 or R7-3 C4-2 C4-3 C8-2 M1-2	R7-3
R7-2 R8 C1 or C2 mapped within R7-2 or R8 C1-6 C1-7 C2-6 C4-4 C4-5 C6-1 C6-2 C8-3 C8-4 M1-3 M1-4 M1-5	R9
R9-1 C1 or C2 mapped within R9-1	R9-1
R9 R10 C1 or C2 mapped within R9 or R10 C1-8 C1-9 C2-7 C2-8 C4-6 C4-7 C5-1 C5-2 C5-3 C5-4 C5-5 C6-4 C6-5 C6-6 C6-7 C6-8 C6-9 M1-6	R10

(d) Medium and high density contextual districts

R6A R6B R7A R7B R7D R7X R8A R8B R8X R9A R9X R10A

C1-6A C1-7A C1-8A C1-8X C1-9A C2-6A C2-7A C2-7X C2-8A C4-2A C4-3A C4-4A C4-4L C4-5A C4-5D C4-5X  
C4-6A C4-7A C5-1A C5-2A C6-2A C6-3A C6-4A

In the districts indicated, and in C1 and C2 Districts mapped within such #Residence Districts#, the height and setback regulations of Section [23-662](#) shall apply. For #Commercial Districts#, the applicable #Residence District# within which such #Commercial District# is mapped, or the applicable residential equivalent set forth in the tables in Section [35-23](#) (Residential Bulk Regulations in Other C1 or C2 Districts or in C3, C4, C5 or C6 Districts) shall be used in applying

such provisions. In addition, in all applicable districts, for #buildings# meeting the criteria set forth in paragraph (a) of Section [23-664](#) (Modified height and setback regulations for certain Inclusionary Housing buildings or affordable independent residences for seniors), the height and setback provisions of paragraph (b) of Section [23-664](#) shall apply. Separate maximum #building# heights are set forth in Sections [23-662](#) and [23-664](#) for #Quality Housing buildings# with #qualifying ground floors# and for those with #non-qualifying ground floors#.

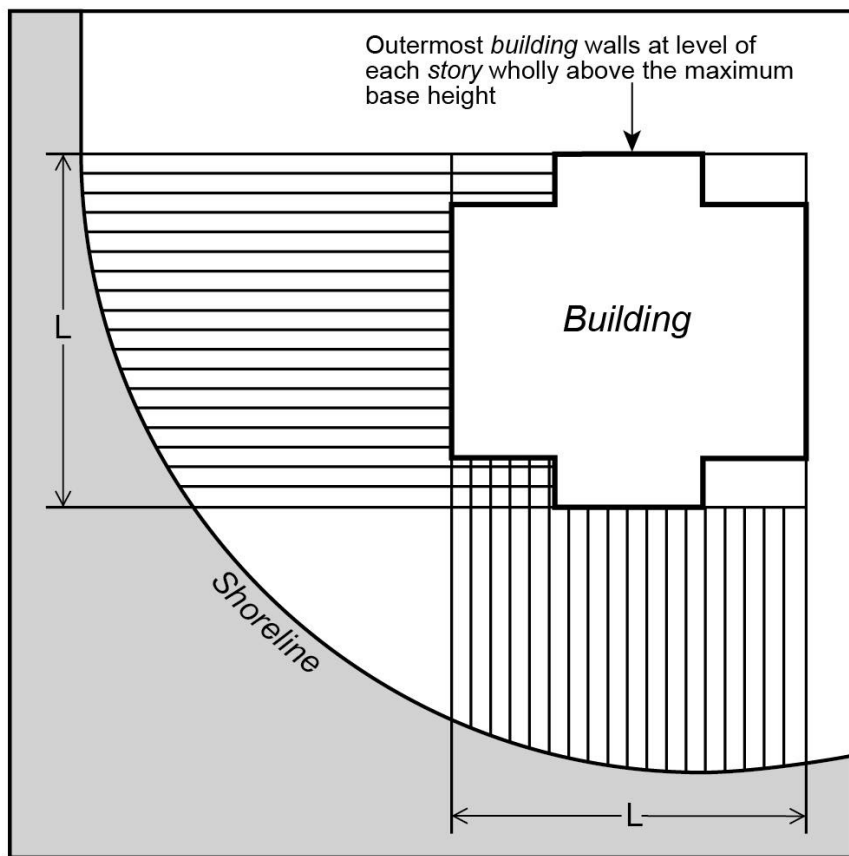

L - Maximum width of *building* wall (100 feet)

MAXIMUM WIDTH OF BUILDING WALL FACING SHORELINE  
(62-341d.1)



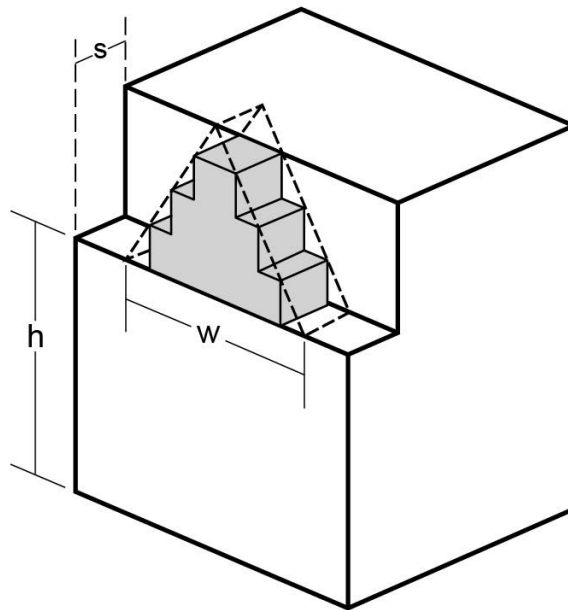

h - Maximum base height

s - Required setback or *initial setback distance*

w - Maximum width of dormer at maximum base height (60% of *street wall* width of highest story entirely below maximum base height)

 Dormer

DORMER  
(62-341d.2)

- (e) C7 Districts and #Manufacturing Districts# with an A suffix

In the districts indicated, the height and setback regulations of Section [33-46](#) (Height and Setback Provisions for C7 Districts) shall apply.