



Zoning Resolution

THE CITY OF NEW YORK

Eric Adams, Mayor

CITY PLANNING COMMISSION

Daniel R. Garodnick, Chair

24-521 - Front setbacks in districts where front yards are required

File generated by <https://zr.planning.nyc.gov> on 2/16/2025

24-521 - Front setbacks in districts where front yards are required

LAST AMENDED

3/22/2016

R1 R2 R3 R4 R5

In the districts indicated, except R5D Districts, where #front yards# are required, the front wall or any other portion of a #building or other structure# shall not penetrate the #sky exposure plane# set forth in the following table:

MAXIMUM HEIGHT OF FRONT WALL AND REQUIRED FRONT SETBACKS

Height above #Front Yard Line# (in feet)	#Sky Exposure Plane#				District
	Slope over #Zoning Lot# (expressed as a ratio of vertical distance to horizontal distance)				
	On #Narrow Street#		On #Wide Street#		
	Vertical Distance	Horizontal Distance	Vertical Distance	Horizontal Distance	
25	1 to	1	1 to	1	R1 R2 R3
35	1 to	1	1 to	1	R4 R5

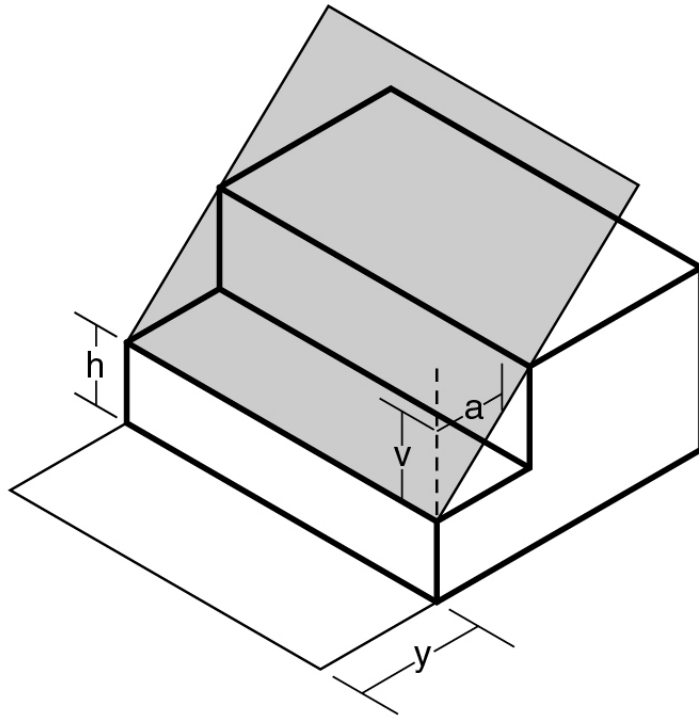

a - Horizontal distance

v - Vertical distance

h - Height of *sky exposure plane*
above *front yard line level*

y - Depth of required
front yard

 *Sky Exposure Plane*

SKY EXPOSURE PLANE

R1, R2, R3, R4, R5 Districts