



Zoning Resolution

THE CITY OF NEW YORK

Eric Adams, Mayor

CITY PLANNING COMMISSION

Daniel R. Garodnick, Chair

118-22 - Street Wall Regulations

File generated by <https://zr.planning.nyc.gov> on 3/27/2025

118-22 - Street Wall Regulations

LAST AMENDED
12/5/2024

The height above #curb level# of the #street wall# of any #development# or #enlargement# shall be as shown in the District Plan (Appendix A). In addition, the following provisions shall apply:

- (a) The #street wall# location provisions of paragraph (a) of Section [35-631](#) (Street wall location) shall apply to all #street walls# except that when a #prevailing street wall frontage# exists, the line-up provisions of paragraph (a) of Section [23-431](#) (Street wall location requirements) shall apply. For the purposes of applying #street wall# location regulations, all streets shall be considered as #wide streets#.
- (b) #Street wall# recesses are permitted below the level of the second #story# ceiling for subway stair entrances required under Section [118-50 118-30](#) (OFF STREET RELOCATION OF A SUBWAY STAIR WITHIN THE SPECIAL UNION SQUARE DISTRICT). Such recesses shall be no longer than 15 feet and no deeper than eight feet or the width or length of the relocated subway stair, whichever is greater.

#Street wall# recesses are also permitted below the level of the second #story# ceiling for #building# or store entrances only.

- (c) On a #zoning lot# where there is an existing #building# to remain, the requirements governing height and location of #street walls# shall not apply within a volume defined by the rear wall of the existing #building# (W_2), the #front lot line# (W_1), the prolongations of the side walls (L) and a height of 125 feet above #curb level#.

If, after January 10, 1985, any demolition or destruction occurs within the volume defined, the requirements governing #street wall# height shall apply.

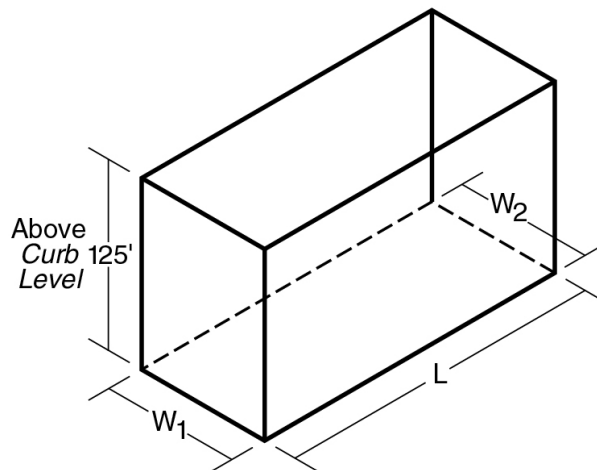

L - Sidewall and prolongation of existing *building*
 W_1 - *Front lot line*
 W_2 - *Rear wall of existing building*

EXISTING BUILDING VOLUME FOR
MODIFICATION OF STREET WALL REQUIREMENTS

- (d) The City Planning Commission may authorize modifications in the required #street wall# location if the Commission finds that the existing #buildings#, or existing open areas serving existing #buildings# to remain on the #zoning lot#,

would be adversely affected by the location of the #street walls# of the #development#, #enlargement# or alteration in a manner prescribed in paragraph (c) of this Section.