



Zoning Resolution

THE CITY OF NEW YORK

Eric Adams, Mayor

CITY PLANNING COMMISSION

Daniel R. Garodnick, Chair

62-56 - Requirements for Upland Connections

File generated by <https://zr.planning.nyc.gov> on 4/4/2025

62-56 - Requirements for Upland Connections

LAST AMENDED
4/22/2009

All waterfront public access areas provided pursuant to Sections 62-53 (Requirements for Shore Public Walkways), 62-54 (Requirements for Public Access on Piers) or 62-55 (Requirements for Public Access on Floating Structures) shall be accessible from an open street, public park or other public place at intervals along the shore public walkway not to exceed 600 feet by means of either a direct connection or, where no direct connection exists, an upland connection between the shore public walkway and an adjoining public sidewalk within an open street, public park or other public place.

Where there is an intervening zoning lot that would prevent compliance with the maximum interval, such interval may be increased to the minimum necessary to clear the intervening zoning lot. In the event there is no way to provide the upland connection without encroaching on an intervening zoning lot, the upland connection shall not be required.

62-561 - Types of upland connections

LAST AMENDED
4/22/2009

Upland connections shall be provided as a single pedestrian walkway pursuant to paragraph (a) of this Section or as two pedestrian walkways pursuant to paragraph (b) of this Section.

(a) Single pedestrian walkway (Type 1)

- (1) The minimum width of an upland connection provided in the form of a single pedestrian walkway (hereinafter referred to as "Type 1") shall be as set forth in the table in this Section. Such widths shall be increased by 20 feet within 15 feet of a street, public park or other public place, hereinafter referred to as an "entry area".

Such widths may be reduced on zoning lots having a lot width less than 150 feet; the minimum width of a single pedestrian walkway may be reduced by an amount equal to one foot for each two feet that the lot is less than 150 feet. However, in no event shall the width be less than the reduced minimum width specified in the table.

MINIMUM WIDTH FOR TYPE 1 UPLAND CONNECTIONS

Districts	Minimum width (in feet)	Reduced minimum width (in feet)
R3 R4 R5 C1 C2 mapped in R1-R5 C3	20	12
R6 R7 R8 R9 R10 C1 C2 C4 C5 C6 C7 C8 M1 M2 M3	30	16

- (2) Where an upland connection does not coincide with a visual corridor, a 20 foot wide open area shall be required seaward of the entry area, and shall extend along the entire remaining length of the upland connection but need not be publicly accessible. This open area may be located on either side of the upland connection or aggregated in any combination, so that the total width of the open area, at any point along the upland connection, is 20 feet. Such increased widths may be modified in accordance with the reduced minimum width provisions in paragraph (a)(1) of this Section.
- (3) Where an upland connection traverses portions of a zoning lot located in districts in which different width requirements apply, the width of the upland connection shall be computed as the weighted average based on the length of the upland connection in each district.

(b) Two pedestrian walkways (Type 2)

- (1) The minimum width of an #upland connection# provided in the form of two pedestrian walkways, one on each side of the roadbed of a private driveway (hereinafter referred to as “Type 2”), shall be 13 feet for each such walkway. However, where a private driveway terminates in a vehicular turnaround, the minimum width of the #upland connection# abutting such turnaround shall be 10 feet.
- (2) In addition, a “transition area” shall be provided which shall have a width equal to the combined width of the Type 2 #upland connection# and the roadbed, and shall extend for a distance of 40 feet measured from the termination of such roadbed in the direction of the #shore public walkway#, as shown in Illustrations 1 and 2 in this Section, for roadbeds that turn and roadbeds that terminate in a turnaround, respectively.

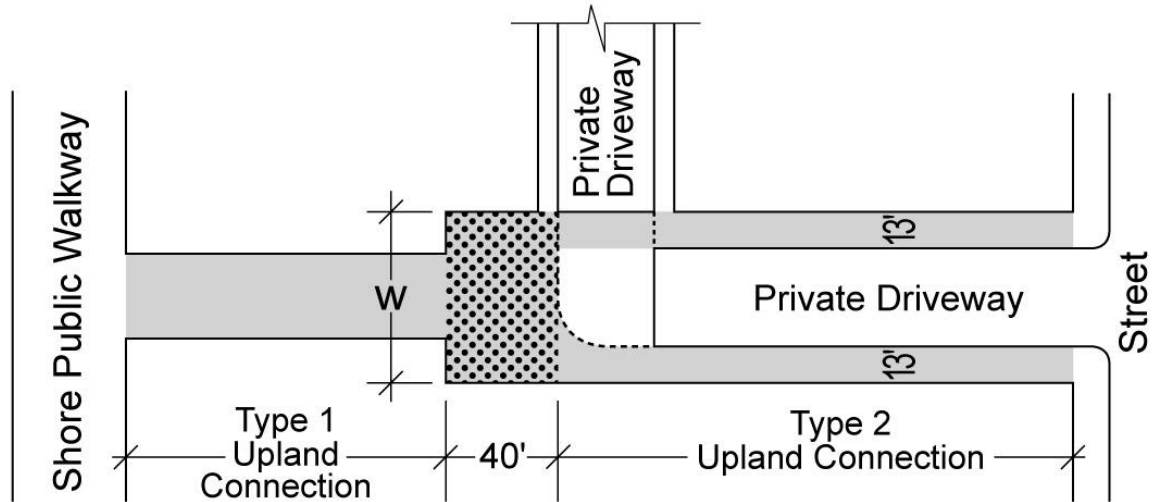

 Upland Connection

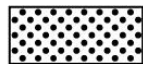
 Transition Area

W Minimum width of Transition Area

Illustration 1: Upland Connection with Roadbed Turn

(62-561b2.1)

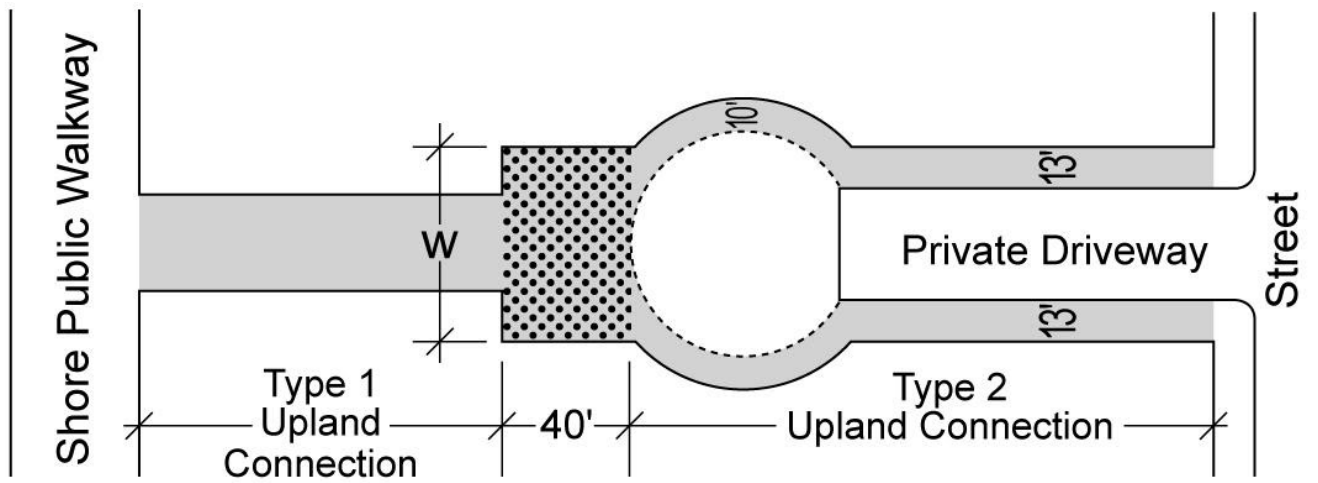

 Upland Connection

 Transition Area

W Minimum width of Transition Area

Illustration 2: Upland Connection with Vehicular Turnaround

(62-561b2.2)

- (3) Such transition area is not required for roadbeds that turn and are located within 15 feet of a #shore public walkway#, or for #waterfront zoning lots# that are less than 255 feet in depth and 260 feet in width. However, for #waterfront zoning lots# that are less than 255 feet in depth and 260 feet in width, an area of at least 10 feet in width shall be provided between the edge of the roadbed and the upland boundary of the #shore public walkway#, as shown in illustration 3.

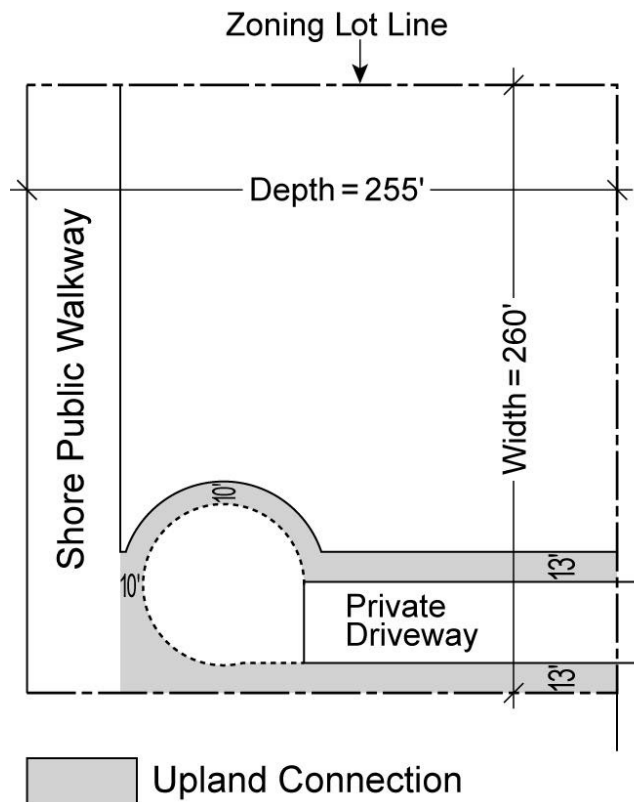

 Upland Connection

Illustration 3: Maximum Zoning Lot Dimensions to Waive Transition Area

(62-561b3)