



Zoning Resolution

THE CITY OF NEW YORK

Eric Adams, Mayor

CITY PLANNING COMMISSION

Daniel R. Garodnick, Chair

23-70 - ALTERNATIVE BULK REGULATIONS FOR CERTAIN AREAS

File generated by <https://zr.planning.nyc.gov> on 3/28/2025

23-70 - ALTERNATIVE BULK REGULATIONS FOR CERTAIN AREAS

LAST AMENDED
12/5/2024

23-71 - Predominantly Built-up Areas

LAST AMENDED
12/5/2024

23-711 - Applicability

LAST AMENDED
12/5/2024

The optional #predominantly built-up area# provisions of Section [23-71](#), inclusive, may be applied to #zoning lots#:

- (a) that have a #lot area# of not more than 1.5 acres;
- (b) located on a #block#:
 - (1) that is entirely within R4 or R5 Districts without a letter or number suffix, including a #Commercial District# mapped within such #Residence Districts#;
 - (2) that has a maximum area of four acres;
 - (3) where the #buildings# on #zoning lots# comprise 50 percent or more of the area of the #block#; and
- (c) where, as of October 21, 1987, not more than 75 percent of the aggregate length of the #block# frontages facing each other around the #zoning lot#, on both sides of the #street#, are allocated to #single-# or #two-family# #detached# or #semi-detached# #residences#.

All #buildings# used in calculations shall have certificates of occupancy or other evidence acceptable to the Commissioner of Buildings issued prior to the date of application for a building permit.

23-712 - Floor area modifications

LAST AMENDED
12/5/2024

For #zoning lots# in R4 or R5 Districts, without a letter or number suffix, utilizing the #predominantly built-up area# provisions of Section [23-71](#), inclusive, the maximum #floor area ratio# shall be as set forth in the following table:

District	Maximum #Floor Area Ratio#
R4	1.35
R5	1.65

23-713 - Height and setback modifications

LAST AMENDED

12/5/2024

For #zoning lots# in R4 or R5 Districts, without a letter or number suffix, utilizing the #predominantly built-up area# provisions of Section [23-71](#), inclusive, the following height and setback modifications shall apply:

- (a) in R4 Districts, the height and setback regulations applicable to an R4A District set forth in Section [23-421](#) (Basic pitched-roof envelopes for certain districts) shall apply; and
- (b) in R5 Districts, the height and setback regulations applicable to an R5B District set forth in Section [23-422](#) (Basic flat-roof envelopes for certain districts) shall apply.

23-72 - Portions of Community District 12 in the Borough of Brooklyn

LAST AMENDED

12/5/2024

23-721 - Applicability

LAST AMENDED

12/5/2024

The optional provisions of Section [23-72](#), inclusive, may be applied to #zoning lots# containing #buildings# used exclusively as #single-#, #two-# or three-#family residences# in R5 and R6 Districts without a letter suffix in the portion of Community District 12, in the Borough of Brooklyn, that is bounded by 39th Street, Dahill Road, Ditmas Avenue, McDonald Avenue, Bay Parkway, 61st Street and Fort Hamilton Parkway.

23-722 - Floor area modifications

LAST AMENDED

12/5/2024

For #zoning lots# in R5 Districts, without a letter suffix, utilizing the provisions of Section [23-72](#), inclusive, the maximum #floor area ratio# shall be as set forth in the following table:

District	Maximum #Floor Area Ratio# for a #corner lot#	Maximum #Floor Area Ratio# for an #interior# or #through lot#
R5	1.65	1.80

23-723 - Yard modifications

LAST AMENDED

12/5/2024

For #zoning lots# utilizing the provisions of Section [23-72](#), inclusive, the #yard# regulations shall be modified as follows:

- (a) in R5 Districts without a letter suffix, the #front yard# regulations shall be modified as follows: a #front yard# shall be provided with a depth of not less than five feet provided that, for #corner lots#, one #front yard# with a depth of not less than 10 feet is required;
- (b) in R5 Districts and R6 Districts without a letter suffix, the #rear yard# regulations shall be modified to require a #rear yard# with a depth of not less than 20 feet at every #rear lot line# on any #zoning lot#.

23-724 - Height and setback modifications

LAST AMENDED
12/5/2024

For #zoning lots# in R5 Districts, without a letter suffix, utilizing the provisions of Section [23-72](#), inclusive, the following height and setback modifications shall apply: the height and setback regulations applicable to an R5B District set forth in Section [23-422](#) (Basic flat-roof envelopes for certain districts) shall apply.

23-73 - Special Provisions for Sky Exposure Plane Buildings

LAST AMENDED
12/5/2024

23-731 - Applicability

LAST AMENDED
12/5/2024

The optional provisions for #sky exposure plane buildings# set forth in Section [23-73](#), inclusive, may be applied to #zoning lots# in R6 through R10 Districts without a letter suffix, except that such alternative provisions shall not apply to:

- (a) #zoning lots# in R6-1, R6-2, R7-3 and R9-1 Districts;
- (b) #zoning lots# in R8 Districts without a letter suffix in the portion of Community District 9 in the Borough of Manhattan located north of West 125th Street; or
- (c) #zoning lots# located in the #Limited Height Districts#.

23-732 - Floor area ratio and open space ratio in R6 through R9 Districts

LAST AMENDED
12/5/2024

R6 R7 R8 R9

In the districts indicated without a letter suffix, for #sky exposure plane buildings#, the minimum required #open space ratio# and the maximum #floor area ratio# for any #zoning lot# shall be determined by the #height factor# of such #zoning lot# as set forth in this Section. Where elected, such #floor area ratio# shall supersede the #floor area ratio# provisions of Section [23-22](#), and apply to all #residences#, including #qualifying affordable housing# or #qualifying senior housing#.

The minimum #open space# required through the application of a minimum #open space ratio# shall be applied in conjunction

with the applicable regulations of Section [23-30](#) (YARDS, COURTS AND OTHER OPEN AREA REGULATIONS). The obstructions set forth in Section [23-311](#) shall per permitted in required #open space#.

MINIMUM REQUIRED OPEN SPACE RATIO AND MAXIMUM FLOOR AREA RATIO

R6 through R9 Districts

For #zoning lots# with a #height factor# of	In R6 Districts		In R7 Districts		In R8 Districts		In R9 Districts	
	Min. Req. #Open Space Ratio#	Max. #Floor Area Ratio#	Min. Req. #Open Space Ratio#	Max. #Floor Area Ratio#	Min. Req. #Open Space Ratio#	Max. #Floor Area Ratio#	Min. Req. #Open Space Ratio#	Max. #Floor Area Ratio#
1	27.5	0.78	15.5	0.87	5.9	0.94	1.0	0.99
2	28.0	1.28	16.0	1.52	6.2	1.78	1.4	1.95
3	28.5	1.62	16.5	2.01	6.5	2.51	1.8	2.85
4	29.0	1.85	17.0	2.38	6.8	3.14	2.2	3.68
5	29.5	2.02	17.5	2.67	7.1	3.69	2.6	4.42
6	30.0	2.14	18.0	2.88	7.4	4.15	3.0	5.08
7	30.5	2.23	18.5	3.05	7.7	4.55	3.4	5.65
8	31.0	2.30	19.0	3.17	8.0	4.88	3.8	6.13
9	31.5	2.35	19.5	3.27	8.3	5.15	4.2	6.54
10	32.0	2.38	20.0	3.33	8.6	5.38	4.6	6.85
11	32.5	2.40	20.5	3.38	8.9	5.56	5.0	7.09
12	33.0	2.42	21.0	3.41	9.2	5.71	5.4	7.30

13	33.5	2.43	21.5	3.42	9.5	5.81	5.8	7.41
14	34.0	2.43	22.0	3.44	9.8	5.92	6.2	7.52
15	34.5	2.43	22.5	3.42	10.1	5.95	6.6	7.52
16	35.0	2.42	23.0	3.41	10.4	5.99	7.0	7.52
17	35.5	2.42	23.5	3.40	10.7	6.02	7.4	7.52
18	36.0	2.40	24.0	3.38	11.0	6.02	7.8	7.46
19	36.5	2.39	24.5	3.36	11.3	6.02	8.2	7.41
20	37.0	2.38	25.0	3.33	11.6	6.02	8.6	7.35
21	37.5	2.36	25.5	3.30	11.9	5.99	9.0	7.25

For #zoning lots# with #height factors# greater than 21, the minimum required #open space ratio# shall be as set forth in the following table:

OPEN SPACE RATIO FOR HIGH BUILDINGS

District	Minimum Required #Open Space Ratio# at #Height Factor# of 21	Additional Required #Open Space Ratio# for each Additional #Height Factor#
R6	37.5	0.5
R7	25.5	0.5
R8	11.9	0.3
R9	9.0	0.4

For these #zoning lots#, the maximum #floor area ratio# shall be such as can be attained at the required #open space ratio# for the #height factor#.*

* The #floor area ratio# attainable at a given #height factor# and a given #open space ratio# may be computed from the

following formula:

$$\frac{1}{\text{FAR}} = \frac{\text{OSR}}{100} + \frac{1}{\text{HF}}$$

23-733 - Floor area ratios in R10 Districts

LAST AMENDED

12/5/2024

In R10 Districts, the maximum #floor area ratio# on a #zoning lot# shall be 12.0 for #qualifying affordable housing# or #qualifying senior housing# and 10.0 for other #residences#.

23-734 - Special tower provisions

LAST AMENDED

12/5/2024

In R9 and R10 Districts, for #zoning lots# containing a #building# that is #developed# or #enlarged# pursuant to the applicable tower regulations of Section [23-737](#) (Tower regulations), the #floor area# provisions of Section [23-241](#) (Special tower provisions) shall apply.

23-735 - Special yard, court and other area regulations

■
LAST AMENDED

12/5/2024

For #sky exposure plane buildings#, the provisions of Section [23-30](#), inclusive, shall apply, except that:

- (a) for #through lots#, the alternate location allowances set forth in paragraph (c)(2) of Section [23-343](#) (Rear yard equivalent requirements) may be applied to #rear yard equivalents#;
- (b) the maximum #lot coverages# set forth in Section [23-36](#), inclusive, need not apply; and
- (c) the minimum distance between #buildings# provisions of paragraph (c)(2) of Section [23-371](#), pertaining to two of more #buildings# on the same #zoning lot# that are not connected at any level, shall be modified as follows.

The required minimum distance between the portion of a #building# containing #dwelling units# and any other #building# on the same #zoning lot# shall vary according to the height of such #building# and the particular wall condition and the presence of #legally required windows# in facing #building# walls.

For the purposes of this Section, wall condition shall be defined as follows:

“wall to wall” is a condition where two walls of #buildings# face each other, and neither wall contains a #legally required window#;

“wall to window” is a condition where two walls of #buildings# face each other, and one wall contains a #legally required window# and the other wall does not contain a #legally required window#;

“window to window” is a condition where two walls of #buildings# face each other, and both walls contain a #legally required window#.

Such minimum distance shall be as indicated in the following table:

Wall Condition	Maximum #building# height above #base plane# or #curb level#, as applicable					
	25 feet	35 feet	40 feet	50 feet	Over 50 feet	
Wall to wall	40	40	40	40	40	
Wall to window	40	40	40	45	50	
Window to window	40	45	50	55	60	

However, for portions of #buildings# higher than 125 feet, the provisions of Section [23-371](#) shall continue to apply.

23-736 - Special height and setback regulations for sky exposure plane buildings

LAST AMENDED
12/5/2024

R6 R7 R8 R9 R10

In the districts indicated without a letter suffix, for #sky exposure plane buildings#, the height and setback regulations shall be as set forth in this Section, inclusive.

#Buildings# may elect to utilize the front setback provisions of paragraph (a) of this Section, or the alternate front setback provisions of paragraph (b) of this Section. Where elected, such provisions shall supersede the provisions of Section [23-43](#), inclusive.

In R9 or R10 Districts, towers may penetrate a #sky exposure plane# pursuant to Section [23-737](#) (Tower regulations).

Notwithstanding the foregoing, for narrow #buildings#, the provisions of Section [23-738](#) shall apply.

(a) Front setbacks

If the front wall or other portion of a #building or other structure# is located at the #street line# or within the #initial setback distance# set forth in the following table, the height of such front wall or other portion of a #building or other structure# shall not exceed the maximum height above the #street line# set forth in the table. Above such specified maximum height and beyond the #initial setback distance#, the #building or other structure# shall not penetrate the #sky exposure plane# set forth in the table, except as otherwise provided in Sections [23-41](#) (Permitted Obstructions) or [23-737](#) (Tower regulations).

MAXIMUM HEIGHT OF FRONT WALL AND REQUIRED FRONT SETBACKS

#Initial Setback Maximum Height Distance# (in feet)		Maximum Height of a Front Wall or other portion of a #Building or Other Structure# within the #Initial Setback Distance#	#Street Line# (in feet)	#Sky Exposure Plane#			
				#Zoning Lot# (expressed as a ratio of vertical distance to horizontal distance)			
On #Narrow Street#	On #Wide Street#			On #Narrow Street#		On #Wide Street#	
				Vertical Distance	Horizontal Distance	Vertical Distance	Horizontal Distance
R6 or R7 Districts							
20	15	60 feet or six #stories#, whichever is less	60	2.7	to 1	5.6	to 1
R8 R9 or R10 Districts							
20	15	85 feet or nine #stories#, whichever is less	85	2.7	to 1	5.6	to 1

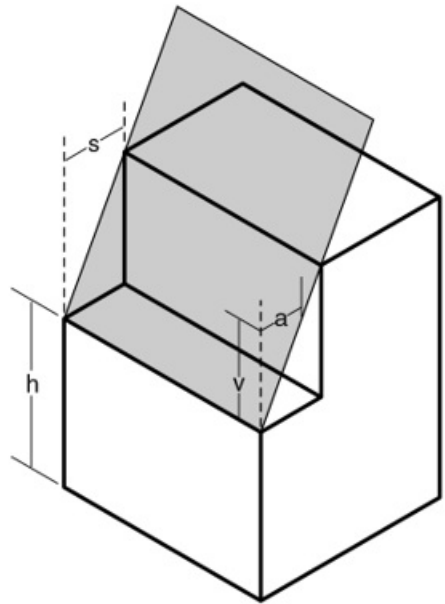

a - Horizontal distance s - Initial setback distance
 h - Height of sky exposure plane above street line v - Vertical distance

Sky Exposure Plane

SKY EXPOSURE PLANE
 R6 R7 R8 R9 R10 Districts

(b) Alternate front setbacks

If an open area is provided along the entire length of the #front lot line# with the minimum depth set forth in the table in this Section, the provisions of this Section may apply in lieu of the provisions of paragraph (a) of this Section. The #building or other structure# shall not penetrate the #sky exposure plane# set forth in the table, except as otherwise provided in Sections [23-41](#) (Permitted Obstructions) or [23-737](#) (Tower regulations).

In R9 or R10 Districts, the provisions of this paragraph shall be inapplicable to any #development# or #enlargement# with more than 25 percent of the total #floor area# of the #building# in #residential use#.

ALTERNATE REQUIRED FRONT SETBACKS

Depth of Optional Front Open Area (in feet, measured perpendicular to #street line#)		Alternate #Sky Exposure Plane#			
		Height above #Street Line# (in feet)	Slope over #Zoning Lot# (expressed as a ratio of vertical distance to horizontal distance)		
On #Narrow Street#	On #Wide Street#		On #Wide Street#		
		Vertical Distance	Horizontal Distance	Vertical Distance	Horizontal Distance
On #Narrow Street#	On #Wide Street#				

R6 or R7 Districts						
15	10	60	3.7	to 1	7.6	to 1
R8 R9 or R10 Districts						
15	10	85	3.7	to 1	7.6	to 1

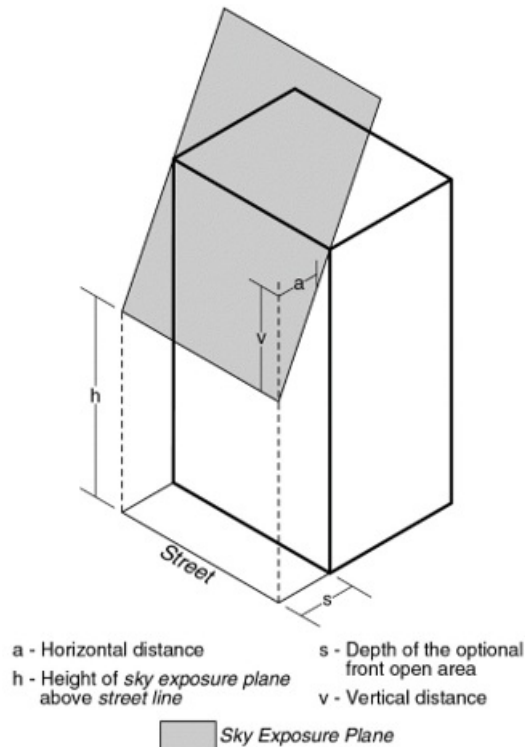

ALTERNATE SKY EXPOSURE PLANE
R6 R7 R8 R9 R10 Districts

23-737 - Tower regulations

LAST AMENDED
12/5/2024

In R9 or R10 Districts, for #buildings# that do not meet the criteria set forth in paragraphs (b)(1) and (b)(2) of Section [23-441](#), a tower may penetrate a #sky exposure plane# provided that such tower:

- (a) does not occupy more than 40 percent of the #lot area# of a #zoning lot# for #zoning lots# with a #lot area# greater than 20,000 square feet, or more than 50 percent of the #lot area# for all other #zoning lots#; and
- (b) is set back at least 10 feet from a #street line# along a #wide street# and at least 15 feet from a #street line# along a #narrow street#.

However, the provisions of this Section shall not apply to any #building# located wholly or partly in a #Residence District#, that is within 100 feet of a #public park# with an area of one acre or more, or a #street line# opposite such a #public park#.

23-738 - Height limitations for narrow buildings or enlargements

LAST AMENDED

12/5/2024

R7-2 R8 R9 R10

In the districts indicated, portions of #buildings# with #street walls# less than 45 feet in width shall not be permitted above the following heights:

- (a) For #interior lots#, and for #through lots#, which shall be treated as two separate #interior lots# of equal depth for the purposes of determining the height limitations of this Section, a height equal to the width of the #street# on which such #street walls# front or 100 feet, whichever is less;
- (b) For #corner lots# bounded by only #narrow streets#, a height equal to the width of the narrowest of such #streets# on which such #street walls# front;
- (c) For #corner lots# bounded by at least one #wide street#, a height equal to the width of the widest #street# on which it fronts, or 100 feet, whichever is less;
- (d) The heights permitted in paragraphs (a), (b) or (c) of this Section may be exceeded if:
 - (1) on a #wide street#, such portion of a #building# with a #street wall# less than 45 feet in width #abuts# an existing #building# with a #street wall# that exceeds such permitted heights. Such new #street walls# may reach the height of such #abutting# #building# or, where there are two #abutting# #buildings# that exceed such heights, such new #street wall# may reach the height of the tallest of such #abutting# #buildings#; or
 - (2) on a #narrow street#, such #street walls# #abut# two existing #buildings# with #street walls# that both exceed the heights permitted. Such new #street walls# may reach the height of the lowest of such #abutting# #buildings#; and
 - (3) such new #street walls# shall be fully contiguous at every level with such #abutting# #street walls#.
- (e) In addition, the following rules shall apply:
 - (1) The front height and setback regulations and any height limitations of the underlying district shall apply, except that the alternate front setback regulations of paragraph (b) of Section [23-736](#) and the tower regulations of Section [23-737](#) shall not apply. In the event of a conflict between the underlying regulations and the regulations of this Section, the more restrictive shall apply.
 - (2) The provisions of this Section shall not apply to #street walls# of permitted obstructions or #street walls# located beyond 100 feet of a #street line#.
 - (3) For the purposes of determining the width of a #street wall#:
 - (i) the width shall be the sum of the maximum widths of all #street walls# of a #building# at every level. The width of a #street wall# shall be the length of the #street line# from which, when viewed directly from above, lines perpendicular to the #street line# may be drawn to such #street wall#; and

- (ii) #abutting# #buildings# on a single #zoning lot# may be considered a single #building#.
- (4) For #buildings# with #street walls# less than 45 feet in width that front only on a #narrow street# and #abut# two existing #buildings#, the #street wall# of such #building# shall be no closer to the #street line# than the #street wall# of the #abutting building# that is closest to the #street line#.
- (5) On a #through lot# containing #buildings# with #street walls# less than 45 feet in width, the alternative location provisions for #rear yard equivalents# set forth in Section [23-735](#) (Special yard, court and other area regulations) shall not apply.