



## Zoning Resolution

THE CITY OF NEW YORK

Eric Adams, Mayor

CITY PLANNING COMMISSION

Daniel R. Garodnick, Chair

# **23-736 - Special height and setback regulations for sky exposure plane buildings**

File generated by <https://zr.planning.nyc.gov> on 3/28/2025

## 23-736 - Special height and setback regulations for sky exposure plane buildings

LAST AMENDED

12/5/2024

R6 R7 R8 R9 R10

In the districts indicated without a letter suffix, for #sky exposure plane buildings#, the height and setback regulations shall be as set forth in this Section, inclusive.

#Buildings# may elect to utilize the front setback provisions of paragraph (a) of this Section, or the alternate front setback provisions of paragraph (b) of this Section. Where elected, such provisions shall supersede the provisions of Section [23-43](#), inclusive.

In R9 or R10 Districts, towers may penetrate a #sky exposure plane# pursuant to Section [23-737](#) (Tower regulations).

Notwithstanding the foregoing, for narrow #buildings#, the provisions of Section [23-738](#) shall apply.

(a) Front setbacks

If the front wall or other portion of a #building or other structure# is located at the #street line# or within the #initial setback distance# set forth in the following table, the height of such front wall or other portion of a #building or other structure# shall not exceed the maximum height above the #street line# set forth in the table. Above such specified maximum height and beyond the #initial setback distance#, the #building or other structure# shall not penetrate the #sky exposure plane# set forth in the table, except as otherwise provided in Sections [23-41](#) (Permitted Obstructions) or [23-737](#) (Tower regulations).

MAXIMUM HEIGHT OF FRONT WALL AND REQUIRED FRONT SETBACKS

#Initial Setback Maximum Distance# (in feet)		Height of a Front Wall or other portion of a #Building or Other Structure# within the #Initial Setback Distance#	#Street Line# (in feet)	#Sky Exposure Plane#			
				#Zoning Lot# (expressed as a ratio of vertical distance to horizontal distance)			
				On #Narrow Street#		On #Wide Street#	
On #Narrow Street#	On #Wide Street#			Vertical Distance	Horizontal Distance	Vertical Distance	Horizontal Distance
R6 or R7 Districts							

20	15	60 feet or six #stories#, whichever is less	60	2.7	to 1	5.6	to 1
R8 R9 or R10 Districts							
20	15	85 feet or nine #stories#, whichever is less	85	2.7	to 1	5.6	to 1

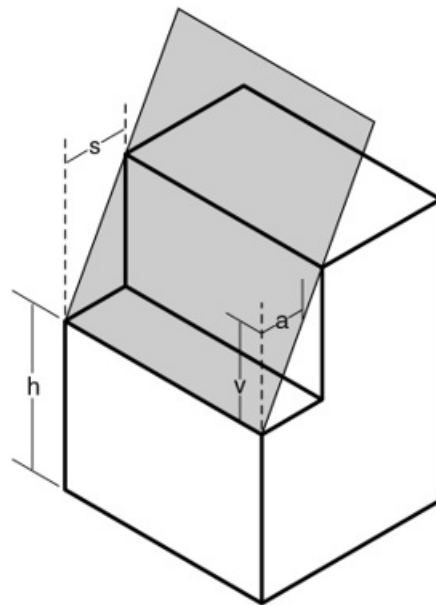

a - Horizontal distance                      s - Initial setback distance  
 h - Height of sky exposure plane above street line      v - Vertical distance

Sky Exposure Plane

**SKY EXPOSURE PLANE**  
 R6 R7 R8 R9 R10 Districts

(b) Alternate front setbacks

If an open area is provided along the entire length of the #front lot line# with the minimum depth set forth in the table in this Section, the provisions of this Section may apply in lieu of the provisions of paragraph (a) of this Section. The #building or other structure# shall not penetrate the #sky exposure plane# set forth in the table, except as otherwise provided in Sections [23-41](#) (Permitted Obstructions) or [23-737](#) (Tower regulations).

In R9 or R10 Districts, the provisions of this paragraph shall be inapplicable to any #development# or #enlargement# with more than 25 percent of the total #floor area# of the #building# in #residential use#.

ALTERNATE REQUIRED FRONT SETBACKS

Depth of Optional Front Open Area (in feet, measured perpendicular to #street line#)	Alternate #Sky Exposure Plane#		#Zoning Lot# (expressed as a ratio of vertical distance to horizontal distance)			
	Height above #Street Line# (in feet)	Slope	On #Narrow Street#		On #Wide Street#	
On #Narrow Street#	On #Wide Street#	Vertical Distance	Horizontal Distance	Vertical Distance	Horizontal Distance	
R6 or R7 Districts						
15	10	60	3.7	to 1	7.6	to 1
R8 R9 or R10 Districts						
15	10	85	3.7	to 1	7.6	to 1

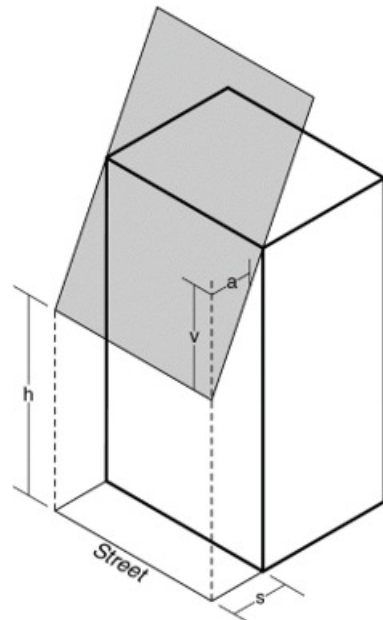

- a - Horizontal distance
  - h - Height of *sky exposure plane* above *street line*
  - s - Depth of the optional front open area
  - v - Vertical distance
- Sky Exposure Plane*

ALTERNATE SKY EXPOSURE PLANE  
 R6 R7 R8 R9 R10 Districts