



Zoning Resolution

THE CITY OF NEW YORK

Eric Adams, Mayor

CITY PLANNING COMMISSION

Daniel R. Garodnick, Chair

23-631 - General provisions

File generated by <https://zr.planning.nyc.gov> on 11/21/2024

23-631 - General provisions

LAST AMENDED
5/12/2021

Height and setback regulations for R1 through R5 Districts are set forth in this Section. Such maximum heights may only be penetrated by permitted obstructions set forth in Section [23-62](#).

R1 R2

- (a) In the districts indicated, except R1-2A, R2A and R2X Districts, the front wall or any other portion of a #building or other structure# shall not penetrate the #sky exposure plane# set forth in the following table:

MAXIMUM HEIGHT OF FRONT WALL AND REQUIRED FRONT SETBACKS

Height above #Front Yard Line# (in ft.)	#Sky Exposure Plane#		District
	Slope over #Zoning Lot# (expressed as a ratio of vertical distance to horizontal distance)		
	Vertical Distance	Horizontal Distance	
25	1 to	1	R1 R2

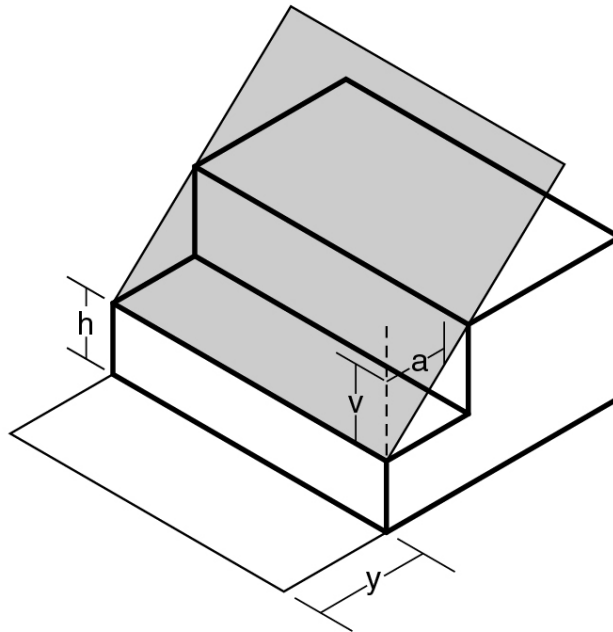

a - Horizontal distance

v - Vertical distance

h - Height of *sky exposure plane* above *front yard line level*

y - Depth of required *front yard*

 *Sky Exposure Plane*

SKY EXPOSURE PLANE

(23-631a, 24-521)

R1-2A R2A R2X R3 R4 R4-1 R4A R5A

(b) In the districts indicated, the height and setback of a #building or other structure# shall be as set forth herein except where modified pursuant to paragraphs (h) and (j) of this Section.

For the purposes of this Section, where #base planes# of different elevations apply to different portions of a #building or other structure#, each such portion of the #building# may be considered to be a separate #building#. Furthermore, for the purposes of this Section, #building segments# may be considered to be separate #buildings# and #abutting# #semi-detached# #buildings# may be considered to be one #building#.

The perimeter walls of a #building or other structure# are those portions of the outermost walls enclosing the #floor area# within a #building or other structure# at any level and height is measured from the #base plane#. Perimeter walls are subject to setback regulations at a maximum height above the #base plane# of:

21 feet	R2A R2X R3 R4A
25 feet	R1-2A R4-1 R4 R5A
26 feet	R3 R4-1 R4A within #lower density growth management areas#

Above these heights, sloping planes control the maximum height of the #building or other structure# requiring either a setback or a pitched roof. These planes start at the maximum permitted height of the perimeter walls and meet at a ridge line of 35 feet above the #base plane#. The exact locations of these planes are flexible and are determined in the steps set forth in paragraphs (b)(1) through (b)(5), as follows:

(1) At a height of 35 feet above and parallel to the #base plane#, a plane is projected above the area enclosed by and including the perimeter walls of the #building or other structure#. A second plane (the perimeter wall plane) is projected in the same manner at a height of 21 or 25 feet above the #base plane#. (See Figure A)

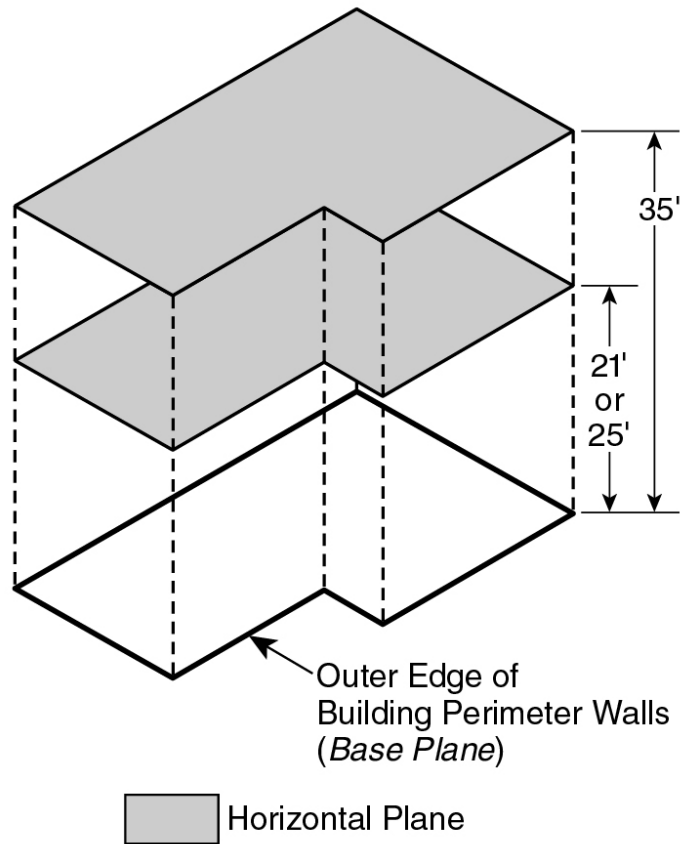

Figure A

(23-631b1)

- (2) Each perimeter wall of the #building or other structure# with a horizontal dimension of eight feet or more which projects from an adjacent perimeter wall at least 18 inches may have an apex point directly above it on the 35 foot high plane. (See Figure B). The location of the apex point is flexible provided it is directly above its perimeter wall and provided a line drawn from the intersection of two perimeter walls to such an apex point does not exceed 80 degrees to the horizontal. An apex point is not required for each qualifying perimeter wall; however, the maximum number of apex points above each such wall is one.

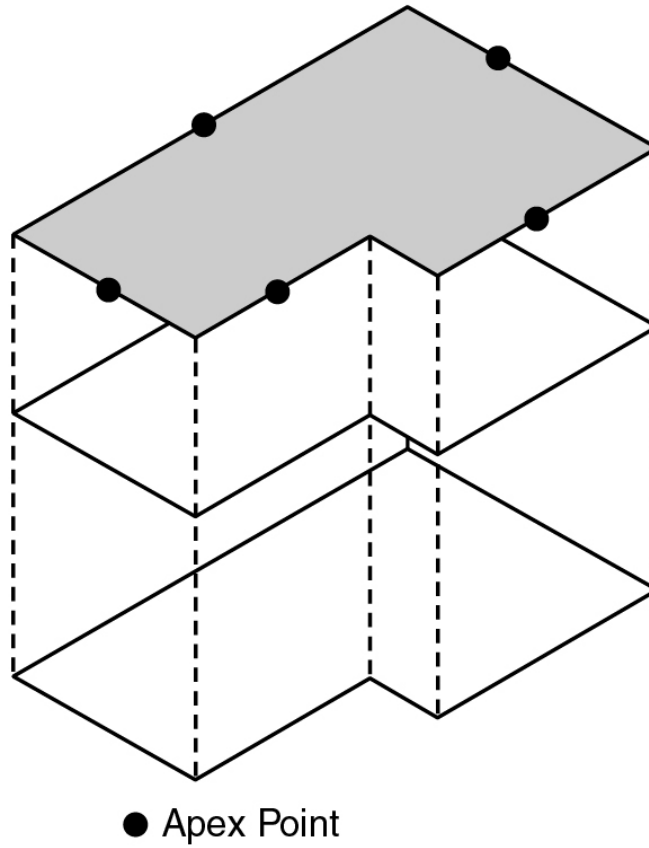
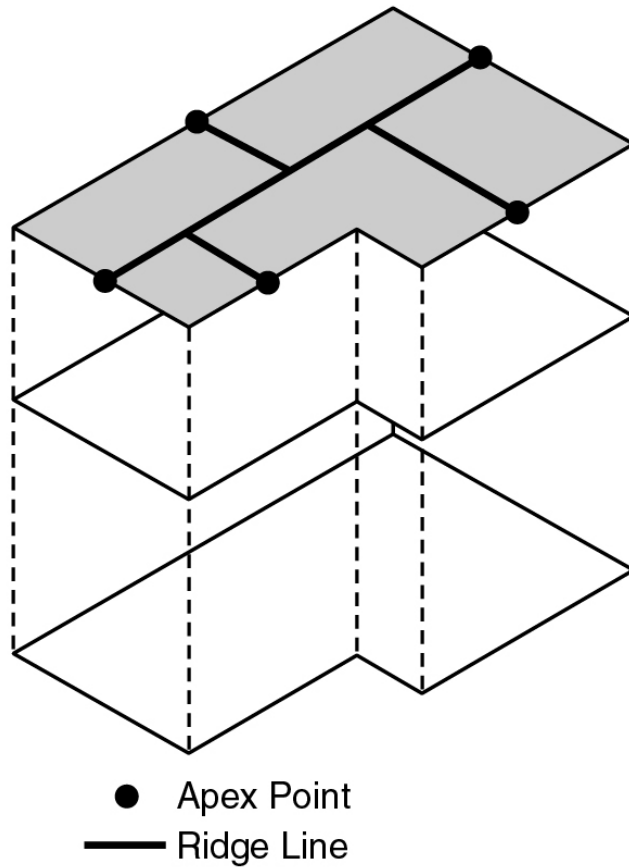

Figure B

(23-631b2)

- (3) One "ridge line" is extended in a straight line from each apex point along the 35 foot high plane. Ridge lines which connect two apex points may cross other ridge lines. Otherwise, ridge lines which extend from only one apex point must terminate at a point of intersection with another ridge line. (See Figure C)



● Apex Point
— Ridge Line

Figure C

(23-631b3)

- (4) Sloping planes are extended in a straight line outward and downward from each ridge line until they intersect the perimeter wall plane. Every sloping plane generated must intersect the perimeter wall plane for the full width of the ridge line from which it extends. (See Figure D). The maximum angle of pitch for any sloping plane may not exceed 80 degrees to the horizontal. Sloping planes extended from ridge lines perpendicular or within 45 degrees of being perpendicular to each other may intersect, in which case the higher plane defines the limit of the envelope. Sloping planes extended from ridge lines parallel or within 45 degrees of being parallel to each other must intersect the perimeter wall plane without intersecting each other.

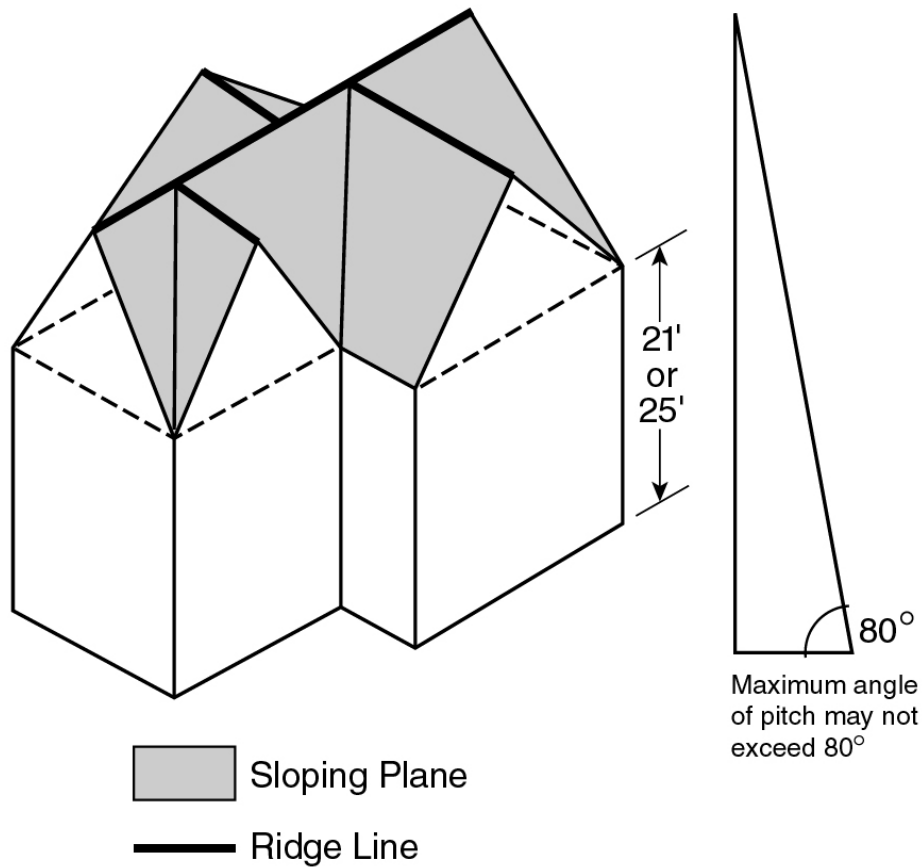
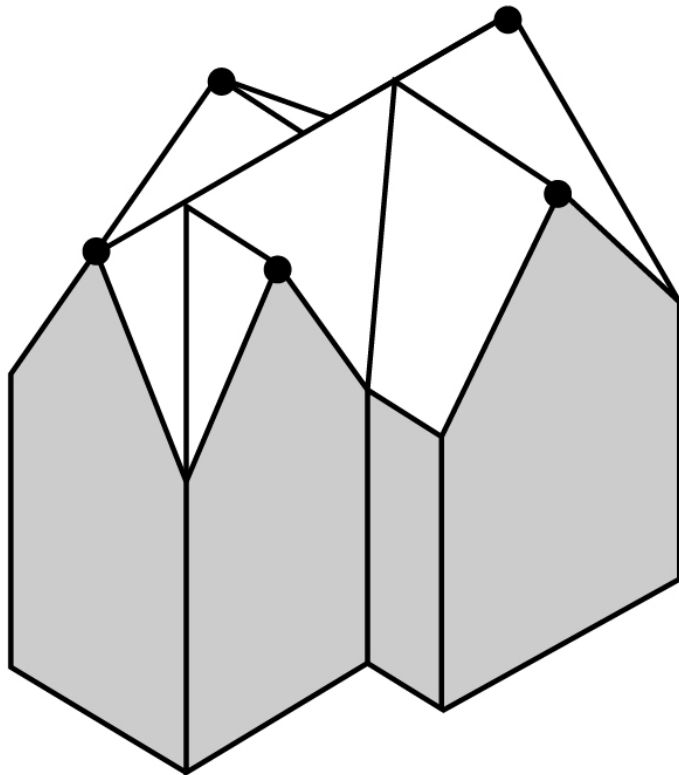

Figure D

(23-631b4)

- (5) The perimeter walls are then extended vertically beyond the perimeter wall plane, up to the heights defined by the sloping planes generated in paragraph (4). (See Figure E). The perimeter walls of the #building# or other structure#, the sloping planes and the perimeter wall extensions define the #building# envelope. (See Figure F). Those items listed in Section [23-44](#) (Permitted Obstructions in Required Yards or Rear Yard Equivalents), and roofed porches and porticoes subject to all applicable provisions, may penetrate the #building# envelope below the maximum permitted perimeter wall height. Eaves may extend the roof lines 18 inches beyond the exterior walls.



Perimeter Wall
Envelope
Extends
vertically to
Apex Points

● Apex Point

(23-631b5.1)

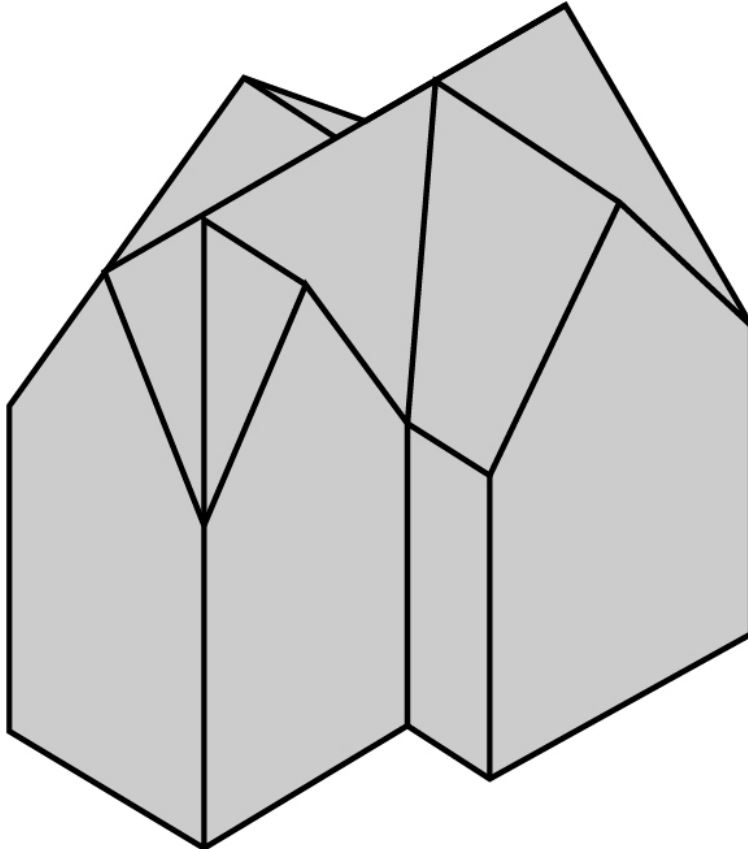

Building
can be
located
anywhere
within
Envelope

Figure E and F

(23-631b5.2)

(6) Special Situations

- (i) For convex curved perimeter walls, the #building or other structure# must be within a plane curve tapering uniformly to a vertex located at a height of 35 feet. For concave curved perimeter walls, the #building or other structure# must lie within a plane curve extending from the maximum perimeter wall height to a ridge line parallel to the prolongation of the perimeter wall at the 35 foot level. Such plane curves may not exceed a pitch of 80 degrees in relation to a plane drawn parallel to the #base plane# at the maximum height of the permitted perimeter wall. (See Figure G).

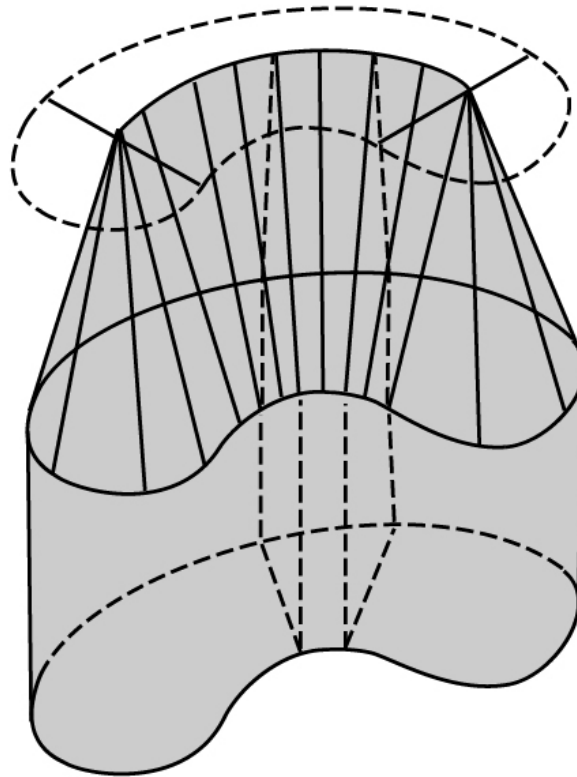

Figure G

(23-631b6.i)

- (ii) In R2X Districts, at the 21 foot maximum permitted height of a perimeter wall, sloping planes are projected inwards and upwards. From a permitted front perimeter wall and from 21 feet above the #base plane# and 20 feet from and parallel to a #rear lot line#, such sloping plane shall not exceed a pitch of 45 degrees in relation to a plane drawn parallel to the #base plane# at a height of 21 feet. (See Figure H). Other sloping planes slope toward a ridge line at 35 feet and may not exceed a pitch of 80 degrees in relation to a plane drawn parallel to the #base plane# at a height of 21 feet.

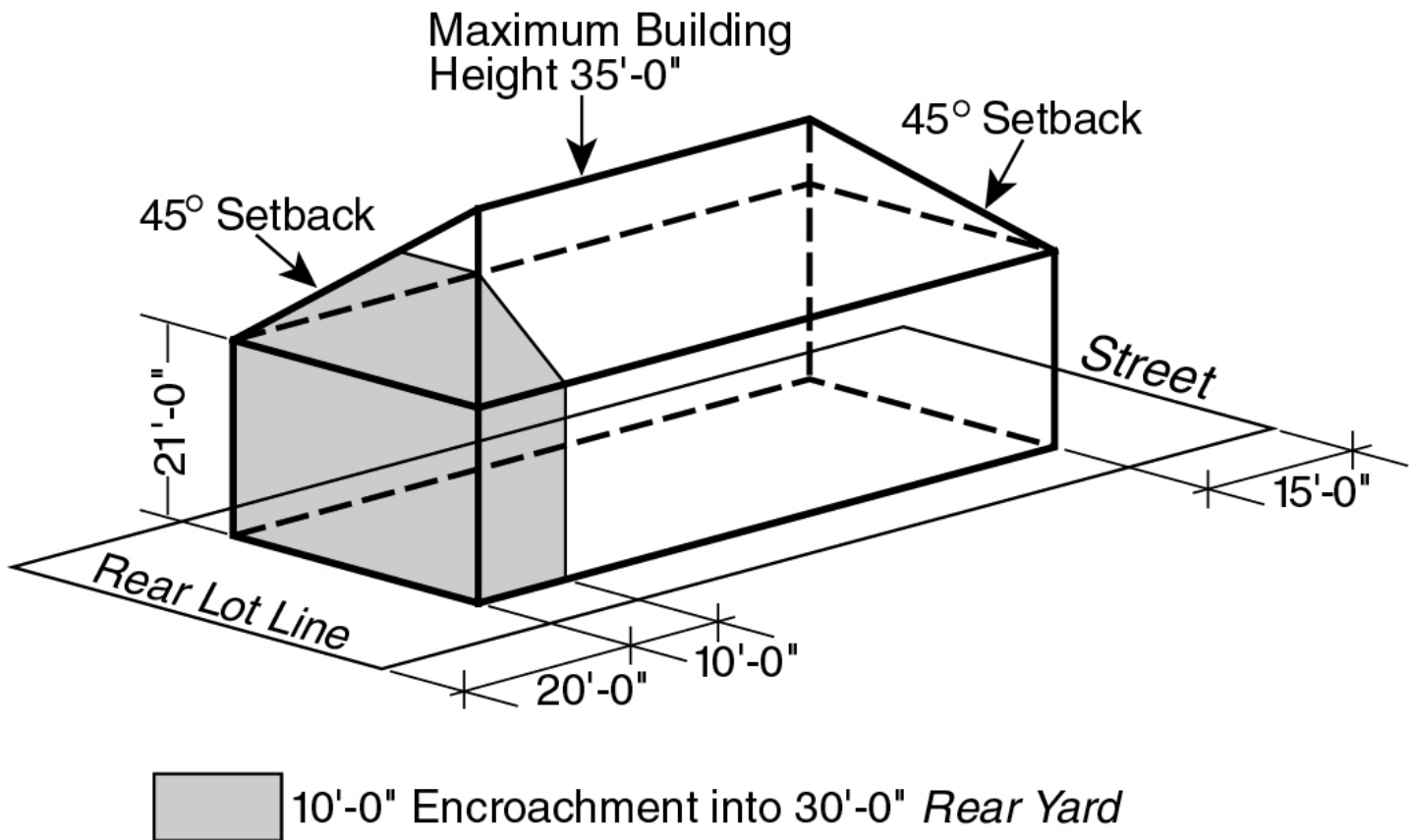

Figure H

(23-631b6.ii)

R4B

- (c) In the district indicated, no portion of the #building or other structure#, including the apex of a roof, shall penetrate a plane 24 feet in height above the #base plane#.

R5

- (d) In the district indicated, except R5A, R5B and R5D Districts, no portion of a #building or other structure#, including the apex of a roof, may penetrate a plane 40 feet above the #base plane#. In addition, the maximum height of a #street wall# above the #base plane# shall be 30 feet. Above such height, a setback of 15 feet is required. Within the setback distance, no portion of the #building or other structure#, including the apex of a roof, may penetrate a plane rising from the maximum #street wall# height, at 20 degrees to the horizontal. On #corner lots#, the 30 foot maximum #street wall# height shall apply to only one #street# frontage. #Buildings or other structures# which utilize the optional regulations of Section [23-143](#) applying to a #predominantly built-up area# shall be subject to the height and setback regulations for an R5B District. The provisions of this paragraph may be modified pursuant to paragraphs (h) and (j) of this Section.

R5B

- (e) In the district indicated, no portion of a #building or other structure#, including the apex of a roof, may penetrate a plane 33 feet above the #base plane#. In addition, the maximum height of a #street wall# above the #base plane# shall be 30 feet. Above such height, no portion of the #building or other structure# shall penetrate a plane rising from the maximum #street wall# height, at 20 degrees to the horizontal, to a maximum height of 33 feet above the #base plane#. On #corner lots#, the 30 foot maximum #street wall# height shall apply to only one #street# frontage. The provisions of this paragraph may be modified pursuant to paragraph (h) of this Section.

R5D

- (f) In the district indicated, no portion of a #building or other structure# shall penetrate a plane 40 feet above the #base plane#. However, where the ground floor level of a #building# provides a #qualifying ground floor# in accordance with the supplemental provisions set forth in paragraph (b)(2) of Section [23-662](#), the maximum height of a #building or other structure# may be increased to 45 feet, or four #stories#, whichever is less.

R3A R4-1 R4A R4B R5B

- (g) In the districts indicated, a second #story# line-up is required as follows:

Where at least 75 percent of the #buildings# containing #residences# within 150 feet of the #side lot lines# of the #zoning lot# have a first #story# front projection that is at least 50 percent of the width of the #building#, the #street wall# shall be no closer to the #street line# than the second #story# #street wall# of an adjacent #building# containing #residences# facing on the same #street#.

Projections from the first #story# #street wall# are permitted provided that such projections are no closer to the #street line# than an adjacent #front yard line#, and such projections are no higher than 13 feet above the #street wall line level#. Projections from the second #story# street wall# are permitted provided that the width of all projections at that level does not exceed 33 percent of the width of the #building# at the second #story#, and the depth of the projections does not exceed three feet.

- (h) The height and setback regulations of this Section are modified as follows:

- (1) In R3-1 and R3-2 Districts, #single-# or #two-family# #detached# #residences# on #zoning lots# of at least 9,500 square feet in area and at least 100 feet of frontage along a #street# may use the height and setback regulations applicable in an R2 District.
- (2) In the #Special Ocean Parkway District#, the #Special Coney Island Mixed Use District#, and the #Special Hunters Point Mixed Use District#, for #buildings or other structures# subject to the regulations of an R5 District other than an R5D District, no portion of a #building or other structure#, including the apex of a roof, may penetrate a plane 40 feet above the #base plane#. In addition, the maximum height of a #street wall# above the #base plane# shall be 32 feet. Above such height, a setback of 15 feet is required. Within the setback distance, no portion of the #building or other structure#, including the apex of a roof, may penetrate a plane rising from the maximum #street wall# height at 20 degrees to the horizontal. On #corner lots#, the 32 foot maximum #street wall# height shall apply to only one #street# frontage.

In these special districts, for #developments# or #enlargements# which utilize the optional regulations applicable to a #predominantly built-up area#, the maximum height of a #building# containing #residences# shall not exceed 32 feet above the #base plane#. Furthermore, for such #developments# or #enlargements# with pitched roofs, the midpoint of such pitched roof shall not exceed a height of 32 feet above the #base plane#. The provisions of this paragraph may be modified pursuant to paragraph (j) of this Section.

- (3) In accordance with Section [78-31](#) (Location of Buildings, Distribution of Bulk and Open Space and Modification of Height and Setbacks), #buildings# within a #large-scale residential development# may use the alternate height and setback regulations set forth in paragraphs (b)(1) through (b)(3) of Section [78-31](#).

R3-2 R4 R5

- (i) In R3-2 Districts, #buildings# containing #affordable independent residences for seniors# may use the height and setback regulations applicable to an R4 District, as set forth in paragraph (b) of this Section.
- (j) In R4 and R5 Districts, except R4-1, R4A, R4B, R5A, R5B and R5D Districts, the height and setback provisions set forth in paragraphs (b) and (d) of this Section shall apply to #buildings# containing #affordable independent residences for seniors#. However, where no #single-family# or #two-family residence# existed on the #zoning lot# within three years prior to the issuance of a building permit for the #development# or #enlargement# of such #building# containing #affordable independent residences for seniors#, such height and setback provisions shall be modified as follows:
 - (1) in R4 Districts, the height of the #building# shall not exceed 45 feet; and
 - (2) in R5 Districts, the height of the #building# shall not exceed 45 feet, except that beyond 25 feet of a #street line#, the height

of the #building# may be increased to a height of 55 feet where one or more of the following conditions are met:

- (i) on the date of application for a building permit for such #development# or #enlargement#, not more than 50 percent of the aggregate length of the #block# frontage on both sides of the #street# facing each other is occupied by #single-family# or #two-family residences#;
- (ii) an existing #building# on the same or adjacent #zoning lot# of such #development# or #enlargement# has a height of 45 feet or more; or
- (iii) the #zoning lot# of such #development# or #enlargement# has a #lot area# of at least 1.5 acres.

(k) In the districts indicated, except R4-1, R4A, R4B, R5A, R5B and R5D Districts, the City Planning Commission may authorize a #building or other structure# that penetrates the height and setback regulations set forth in paragraphs (b), (d) or (i) of this Section, except for #buildings# utilizing the optional regulations for #predominantly built-up areas#. As a condition for granting such authorizations, the Commission shall find that:

- (1) by concentrating permitted #floor area# in a #building# or #buildings# of greater height, the preservation of an existing #building#, topography, vegetation, or view corridors having environmental, historic or aesthetic value to the public will be assured, and that such preservation would not be possible by careful siting of lower #buildings# containing the same permitted #floor area#; or, for #affordable independent residences for seniors#, the additional #floor area# permitted is accommodated in an efficient manner;
- (2) such modification is the least modification required to achieve the purpose for which it is granted;
- (3) the proposed modification does not impair the essential character of the surrounding area; and
- (4) the proposed modification will not have adverse effects upon light, air, and privacy of adjacent properties and of any existing #buildings# on the #zoning lot#.

Applications for authorizations shall be referred to the affected Community Board for a period of at least 30 days for comment. The Commission shall grant in whole or in part or deny the application within 60 days of the completion of the Community Board review period.