



Zoning Resolution

THE CITY OF NEW YORK
Zohran K. Mamdani, Mayor

CITY PLANNING COMMISSION
Sideya Sherman, Chair

24-522 - Front setbacks in districts where front yards are not required

File generated by <https://zr.planning.nyc.gov> on 6/11/2026

24-522 - Front setbacks in districts where front yards are not required

LAST AMENDED

12/5/2024

R6 R7 R8 R9 R10 R11 R12

In the districts indicated without a letter suffix, if the front wall or other portion of a #building or other structure# is located at the #street line# or within the #initial setback distance# set forth in the table in this Section, the height of such front wall or other portion of a #building or other structure# shall not exceed the maximum height above #curb level# set forth in the table. Above such specified maximum height and beyond the #initial setback distance#, the #building or other structure# shall not penetrate the #sky exposure plane# set forth in the table:

MAXIMUM HEIGHT OF FRONT WALL AND REQUIRED FRONT SETBACKS

#Initial Setback Distance# (in feet)		Maximum Height of a Front Wall or other portion of a #Building or other structure# within the	#Sky Exposure Plane#				
		#Initial Setback Distance#	Height above #Street Line# (in feet)	Slope over #Zoning Lot# (expressed as a ratio of vertical distance to horizontal distance)			
				On #Narrow Street#	On #Wide Street#		
On #Narrow Street#	On #Wide Street#			Vertical Distance	Horizontal Distance	Vertical Distance	Horizontal Distance
20	15	60 feet or six #stories#, whichever is less	60	2.7	to 1	5.6	to 1

R8, R9, R10, R11 or R12 Districts

20 15 85 feet or 85 2.7 to 1 5.6 to 1

nine

#stories#,

whichever is

less

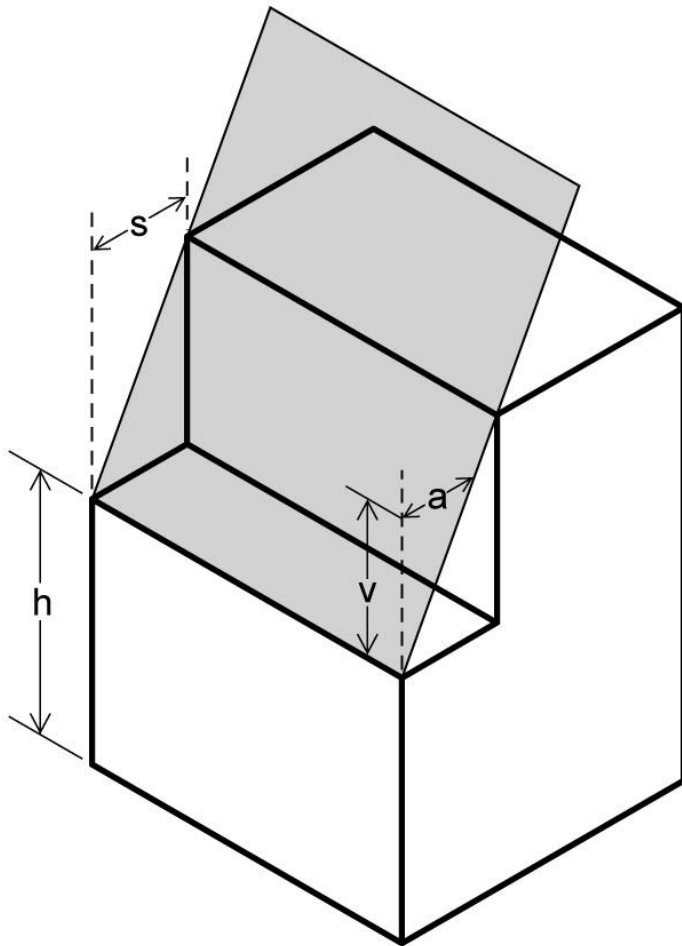

a - Horizontal distance s - Initial setback distance

h - Height of sky exposure plane above street line v - Vertical distance

 Sky Exposure Plane

SKY EXPOSURE PLANE

R6, R7, R8, R9, R10, R11, R12 Districts