



## Zoning Resolution

THE CITY OF NEW YORK

Eric Adams, Mayor

CITY PLANNING COMMISSION

Daniel R. Garodnick, Chair

# **24-52 - Maximum Height of Walls and Required Setbacks**

File generated by <https://zr.planning.nyc.gov> on 12/16/2024

## 24-52 - Maximum Height of Walls and Required Setbacks

LAST AMENDED

6/29/1994

R1 R2 R3 R4 R5 R6 R7 R8 R9 R10

In all districts, as indicated, the maximum height of a front wall or of any other portion of a #building or other structure# shall be as set forth in this Section, except as otherwise provided in Section [24-51](#) (Permitted Obstructions), [24-53](#) (Alternate Front Setbacks), [24-54](#) (Tower Regulations) or [23-692](#) (Height limitations for narrow buildings or enlargements).

## 24-521 - Front setbacks in districts where front yards are required

LAST AMENDED

3/22/2016

R1 R2 R3 R4 R5

In the districts indicated, except R5D Districts, where #front yards# are required, the front wall or any other portion of a #building or other structure# shall not penetrate the #sky exposure plane# set forth in the following table:

### MAXIMUM HEIGHT OF FRONT WALL AND REQUIRED FRONT SETBACKS

Height above #Front Yard Line# (in feet)	#Sky Exposure Plane#				District	
	Slope over #Zoning Lot# (expressed as a ratio of vertical distance to horizontal distance)					
	On #Narrow Street#		On #Wide Street#			
	Vertical Distance	Horizontal Distance	Vertical Distance	Horizontal Distance		
25	1 to	1	1 to	1	R1 R2 R3	
35	1 to	1	1 to	1	R4 R5	

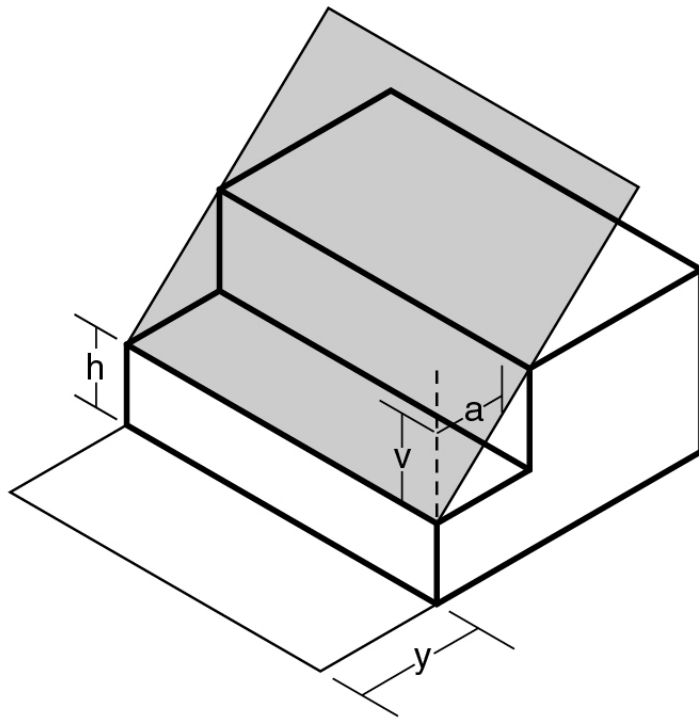

a - Horizontal distance

v - Vertical distance

h - Height of *sky exposure plane* above *front yard line level*

y - Depth of required *front yard*

 *Sky Exposure Plane*

SKY EXPOSURE PLANE

R1, R2, R3, R4, R5 Districts

**24-522 - Front setbacks in districts where front yards are not required**

LAST AMENDED

3/22/2016

R6 R7 R8 R9 R10

In the districts indicated without a letter suffix, for #buildings# other than #Quality Housing buildings#, if the front wall or other portion of a #building or other structure# is located at the #street line# or within the #initial setback distance# set forth in the table in this Section, the height of such front wall or other portion of a #building or other structure# shall not exceed the maximum height above #curb level# set forth in the table. Above such specified maximum height and beyond the #initial setback distance#, the #building or other structure# shall not penetrate the #sky exposure plane# set forth in the table:

MAXIMUM HEIGHT OF FRONT WALL AND REQUIRED FRONT SETBACKS

#Initial Setback Distance# (in feet)	Maximum Height of a Front Wall or other portion of a #Building or	#Sky Exposure Plane#	
		Height above #Street Line# (in	Slope over #Zoning Lot# (expressed as a ratio of vertical distance to horizontal distance)
	#Building or		

		other structure# within the #Initial Setback Distance#	feet)	On #Narrow Street#		On #Wide Street#	
On #Narrow Street#	On #Wide Street#			Vertical Distance	Horizontal Distance	Vertical Distance	Horizontal Distance
R6 or R7 Districts							
20	15	60 feet or six #stories#, whichever is less	60	2.7	to 1	5.6	to 1
R8, R9 or R10 Districts							
20	15	85 feet or nine #stories#, whichever is less	85	2.7	to 1	5.6	to 1

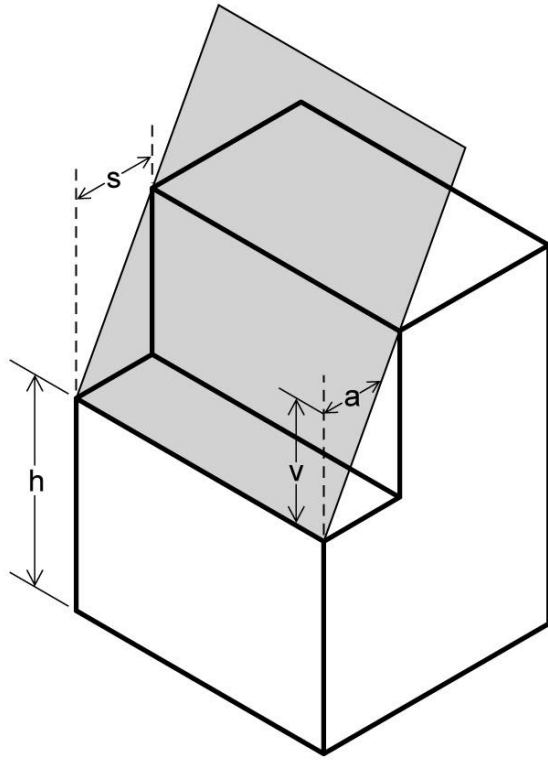

a - Horizontal distance                      s - Initial setback distance  
 h - Height of sky exposure plane above street line      v - Vertical distance

 Sky Exposure Plane

SKY EXPOSURE PLANE  
 R6, R7, R8, R9, R10 Districts