



Zoning Resolution

THE CITY OF NEW YORK

Eric Adams, Mayor

CITY PLANNING COMMISSION

Daniel R. Garodnick, Chair

43-43 - Maximum Height of Front Wall and Required Front Setbacks

File generated by <https://zr.planning.nyc.gov> on 3/28/2025

43-43 - Maximum Height of Front Wall and Required Front Setbacks

LAST AMENDED

6/6/2024

M1 M2 M3

In all districts, other than districts with an A suffix, if the front wall or any other portion of a #building or other structure# is located at the #street line# or within the #initial setback distance# as set forth in the table in this Section, the height of such front wall or other portion of a #building or other structure#, except as otherwise set forth in this Section, shall not exceed the maximum height above #curb level# set forth in the table. Above such maximum height and beyond the #initial setback distance#, the #building or other structure# shall not penetrate the #sky exposure plane# set forth in the table.

The regulations of this Section shall apply, except as otherwise provided in Sections [43-42](#) (Permitted Obstructions), [43-44](#) (Alternate Front Setbacks) or [43-45](#) (Tower Regulations). In M1-1 Districts, for #community facility buildings#, the maximum height of a front wall shall be 35 feet or three #stories#, whichever is less, and the height above the #street line# shall be 35 feet, and in M1-4 Districts, for #community facility buildings#, the maximum height of a front wall shall be 60 feet or six #stories#, whichever is less.

For #zoning lots# in M1-6 Districts that are both within 100 feet of the western #street line# of Seventh Avenue and between West 28th and West 30th Streets in the Borough of Manhattan, the following #street wall# regulations shall apply to #street# frontages not occupied by a #public plaza#. The #street wall# of a #building# shall be located on the #street line# and extend along the entire #street# frontage of the #zoning lot# up to a minimum height of 125 feet or the height of the #building#, whichever is less, and a maximum height of 150 feet. Above a height of 150 feet, no portion of a #building# may penetrate a #sky exposure plane# except for towers, pursuant to Section [43-45](#). The #sky exposure plane# shall begin at a height of 150 feet above the #street line# and rise over the #zoning lot# at a slope of 5.6 feet of vertical distance for each foot of horizontal distance on a #wide street#, and at a slope of 2.7 feet of vertical distance for each foot of horizontal distance on a #narrow street#. The provisions of Section [43-44](#) shall not apply. On the ground floor, recesses shall be permitted where required to provide access to the #building#, provided such recesses do not exceed three feet in depth as measured from the #street line#. Above the level of the second #story#, up to 30 percent of the #aggregate width of street walls# may be recessed beyond the #street line#. However, no recesses shall be permitted within 20 feet of an adjacent #building# and within 30 feet of the intersection of two #street lines#.

MAXIMUM HEIGHT OF FRONT WALL AND REQUIRED FRONT SETBACKS

#Initial Setback Distance# (in feet)		Maximum Height of a Front Wall, or other Portion of a #Building or other structure# within the #Initial Setback Distance#	#Sky Exposure Plane#				
			Height above #Street Line# (in feet)	Slope over #Zoning Lot# (expressed as a ratio of vertical distance to horizontal distance)			
On #Narrow Street#	On #Wide Street#			On #Narrow Street#		On #Wide street#	
			Vertical Distance	Horizontal Distance	Vertical Distance	Horizontal Distance	
Within M1-1 Districts							

20	15	30 feet or 2 #stories#, whichever is less	30	1 to	1	1 to	1
Within M1-2, M1-4, M2-1, M2-3 or M3 Districts							
20	15	60 feet or 4 #stories#, whichever is less	60	2.7 to	1	5.6 to	1
Within M1-3, M1-5, M1-6, M2-2 or M2-4 Districts							
20	15	85 feet or 6 #stories#, whichever is less	85	2.7 to	1	5.6 to	1

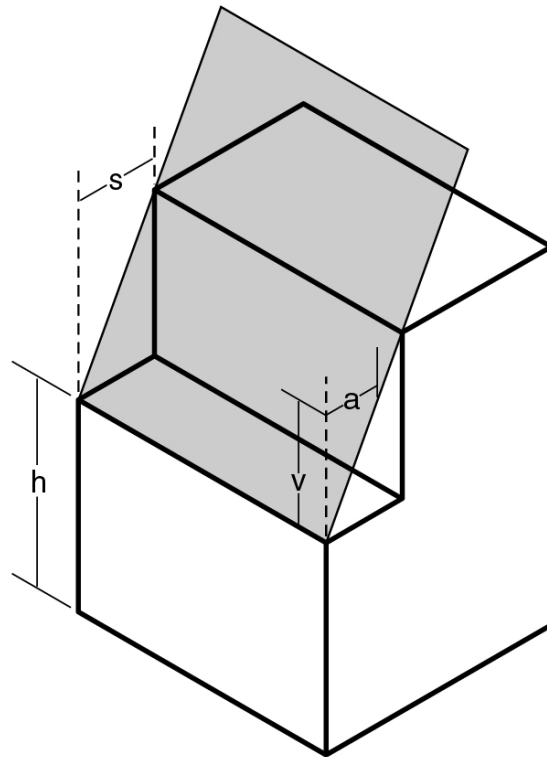

a - Horizontal distance s - Initial setback distance
 h - Height of sky exposure plane above street line v - Vertical distance

 Sky Exposure Plane

SKY EXPOSURE PLANE

(23 - 641, 24 - 522, 33 - 432, 43 - 43)